

# BMS8780T Modernist 8 x 7 Dual Barn Door Storage Shed

## ASSEMBLY INSTRUCTIONS

### Tools Required

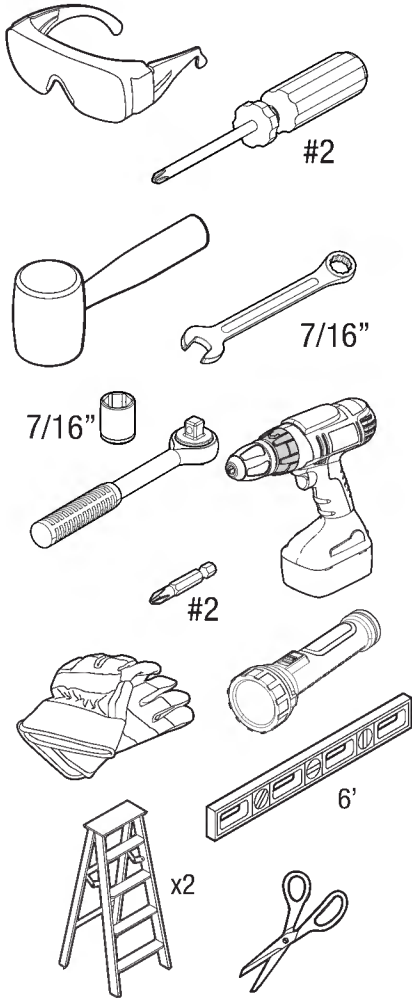

### INCLUDED IN KIT

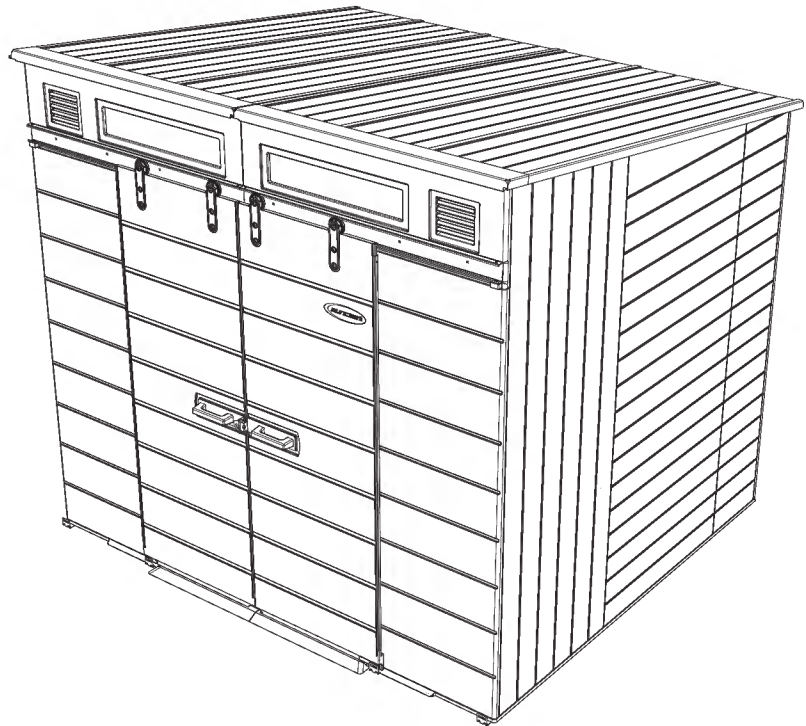
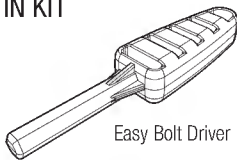

Scan QR Code for product assembly video.

**SUNCAST**<sup>®</sup>

Built for Everyday Life™

# Register within 90 days of purchase to activate Warranty!

Registration is not required for products with a warranty term of 90 days or less.



1. Verify warranty term of your product by visiting [www/suncast.com/warranty](http://www.suncast.com/warranty) (products with a warranty term of 90 days or less do not require registration)
2. Complete registration: fill out the form and upload a copy of your receipt by visiting <https://support.suncast.com> or scanning the QR code

## Have Questions?

For product questions, assembly assistance, replacement parts and more:



<https://support.suncast.com>



Suncast Corporation Customer Care  
701 N. Kirk Road, Batavia, IL 60510



1-800-846-2345

1-630-381-6309



## Before You Begin...

- **Consult your local authorities for any permits required to construct shed.**

Prior to the construction of your shed, check with the local building code official to review any required permits or building limitations.

- **A level and sturdy foundation is required before shed construction can begin.**

Site preparation information is available later on in this manual. A foundation that differs from the specifications within this manual could prevent proper assembly and may damage parts.

- **Read instructions thoroughly prior to assembly.**

This kit contains parts that can be damaged if assembled incorrectly or in the wrong sequence.

- **Please follow instructions.**

Suncast is not responsible for replacing parts lost or damaged due to incorrect assembly.

- **Assistance is required during entire assembly.**



Indicates at least 1 additional adult is needed to complete this step.



Indicates caution is recommended when using a power drill.

### **IMPORTANT**

**COMPLETE SITE PREPARATION AND FOUNDATION CONSTRUCTION BEFORE UNPACKING ALL PARTS.**

**OPEN ALL BOXES FIRST AND NEATLY LAYOUT PARTS. SMALL PARTS MAY BE CONTAINED IN EACH BOX. PLEASE REFERENCE THE PARTS LIST WITHIN THIS MANUAL TO VERIFY ALL PARTS ARE PRESENT.**



## Caution

- Power tools can apply excessive torque resulting in damage to the product. If you choose to use a power drill to assemble the product, Suncast recommends using a variable speed, cordless drill with a variable clutch set at the lowest setting. A #2 Phillips driver bit is compatible with the hardware provided. Suncast makes no guarantee that following this recommendation will prevent damage to the product. Damage to parts due to over-torque are not covered under Suncast's limited-warranty.
- Proper site preparation required.
- Shed not intended for storage of flammable, caustic or corrosive materials.
- Shed not intended for habitation or for use by children.
- **DO NOT** stand, sit, or store items on storage shed roof.
- Repair or replace broken parts immediately.
- **DO NOT** place near objects that are hot or can become hot.
- Heavy articles should not be leaned against the walls, as this may cause panel distortion and permanent damage.
- Suncast is not responsible for damage caused by weather or misuse.
- This kit contains parts with sharp edges. Please be careful when handling, use of work gloves is recommended.
- **WHEN DRILLING THROUGH METAL**, beware of burrs, shavings and other sharp edges. Safety glasses are strongly recommended.
- **DO NOT** place in areas near highly reflective surfaces (Note: Low-E windows are more reflective than standard windows and may affect the longevity of the product).
- Product is water resistant and not waterproof. Locate unit away from gutter and down spouts for optimal performance.



## Shed Care and Maintenance

- At regular intervals, inspect your shed to make sure that assembly integrity has been maintained.
- Periodically check that the location you have chosen to set your shed is still level.
- Keep roof clean of snow and leaves.
- To maintain the look of your product, we recommend cleaning it at regular intervals with mild soap and water. **DO NOT** use bleach, ammonia or other caustic cleaners, and **DO NOT** use stiff bristle brushes. Failure to perform cleaning at regular intervals could result in permanent staining of the plastic. This type of damage is not covered under warranty.



## Assembly Day Tips

- **DO NOT** attempt to assemble on a day with strong winds.
- Set aside appropriate amount of time to completely assemble shed. An incomplete shed assembly may pose a safety hazard.
- Make sure you have assistance nearby to lift and secure parts in place.
- Once roof is assembled, a flashlight may be of use when assembling smaller components inside shed.
- **DO NOT** use a torque wrench or hand drill to tighten Easy bolts. Use provided Easy Bolt Driver ONLY.
- Suncoast provides extra hardware for small fasteners for customer convenience. In some cases, there will be extra small fasteners once the assembly is complete.

**Note:** This product contains parts that are used in different orientations to construct the shed. Please take note of the orientation of the parts shown throughout this instruction manual. Failure to follow instructions could result in damage to parts. Suncoast is not responsible for replacing parts lost or damaged due to incorrect assembly.

# Parts - Panels

## IMPORTANT

COMPLETE SITE PREPARATION AND FOUNDATION CONSTRUCTION BEFORE UNPACKING ALL PARTS.

OPEN ALL BOXES FIRST AND NEATLY LAYOUT PARTS. SMALL PARTS MAY BE CONTAINED IN EACH BOX. PLEASE REFERENCE THE PARTS LIST WITHIN THIS MANUAL TO VERIFY ALL PARTS ARE PRESENT.

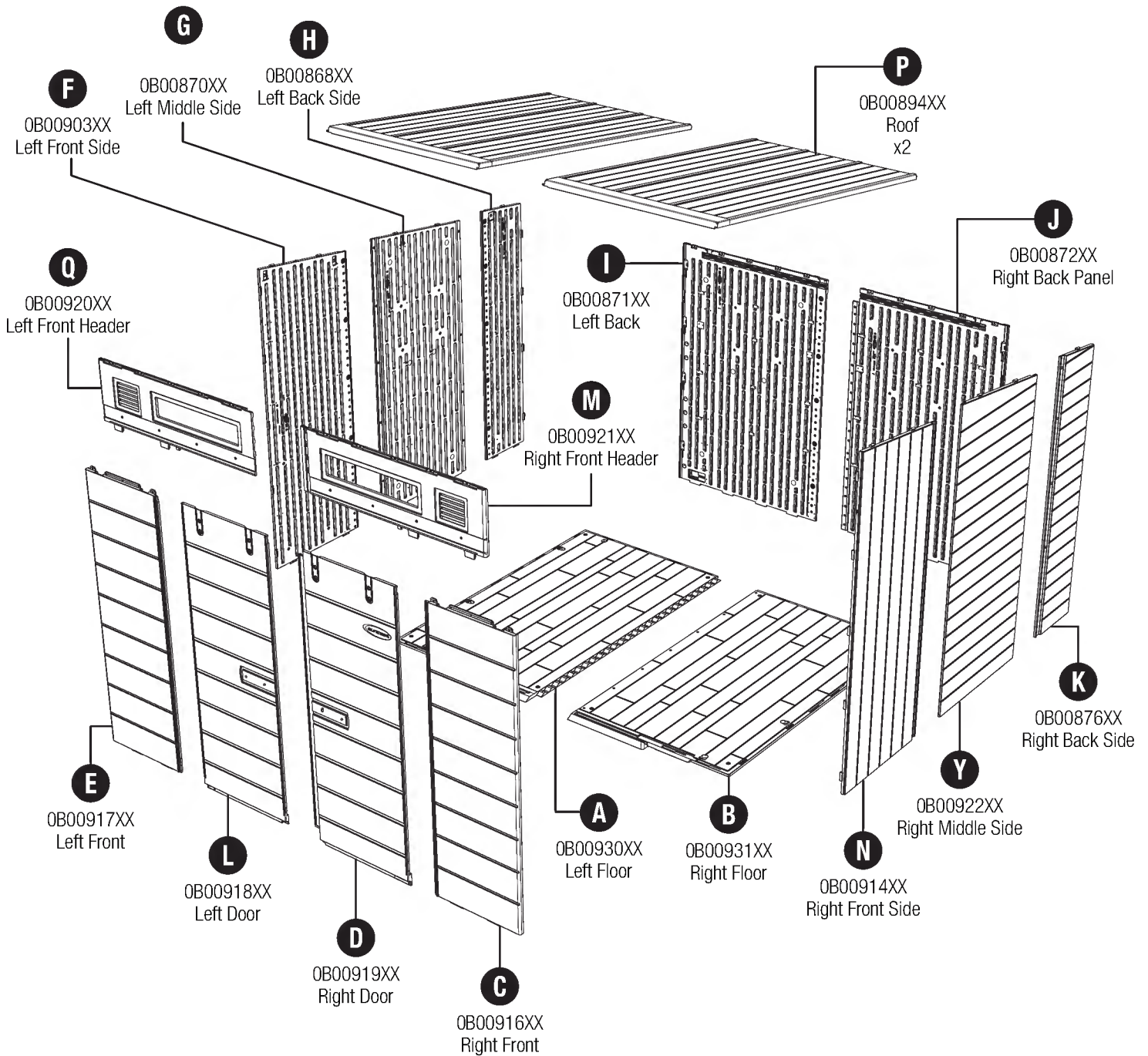

# Parts - Steel

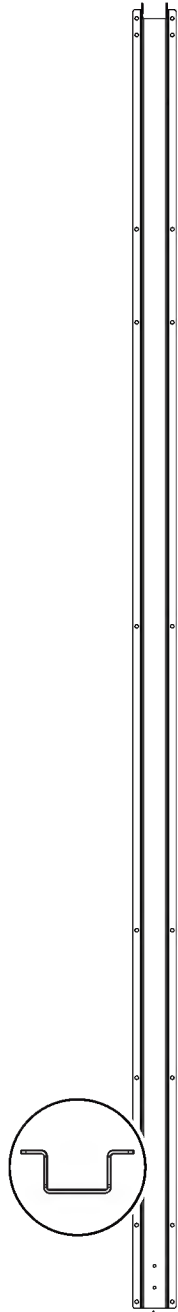

1MRG04005A  
68.5" Side Adapter  
x4

**Steel Kit #1: 0860129**

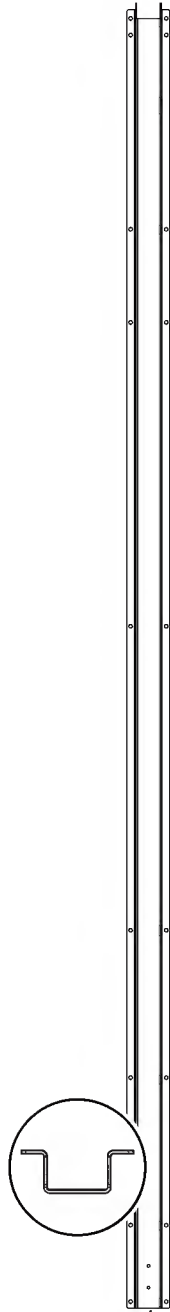

1MRG04005A  
68.5" Side Adapter  
x2

**Steel Kit #2: 0860130**

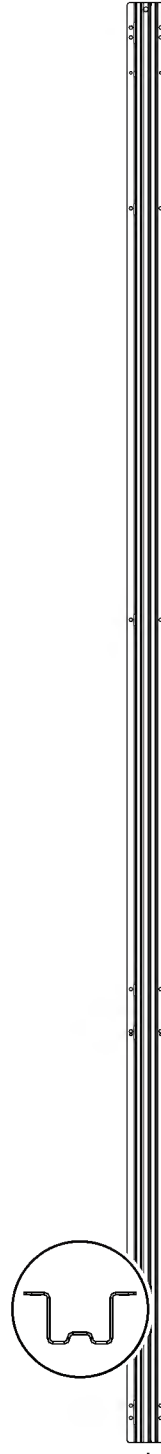

1MRG05006A  
82.94" Truss Leg  
x3

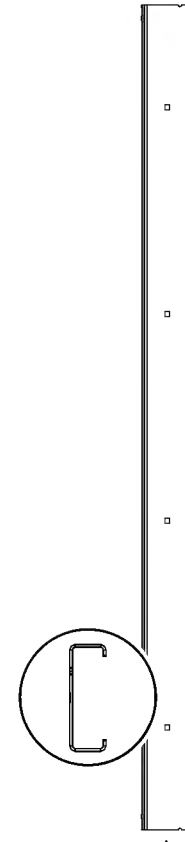

0MR011002  
47.5" Door Track  
x2

**Door Kit: 0860132**

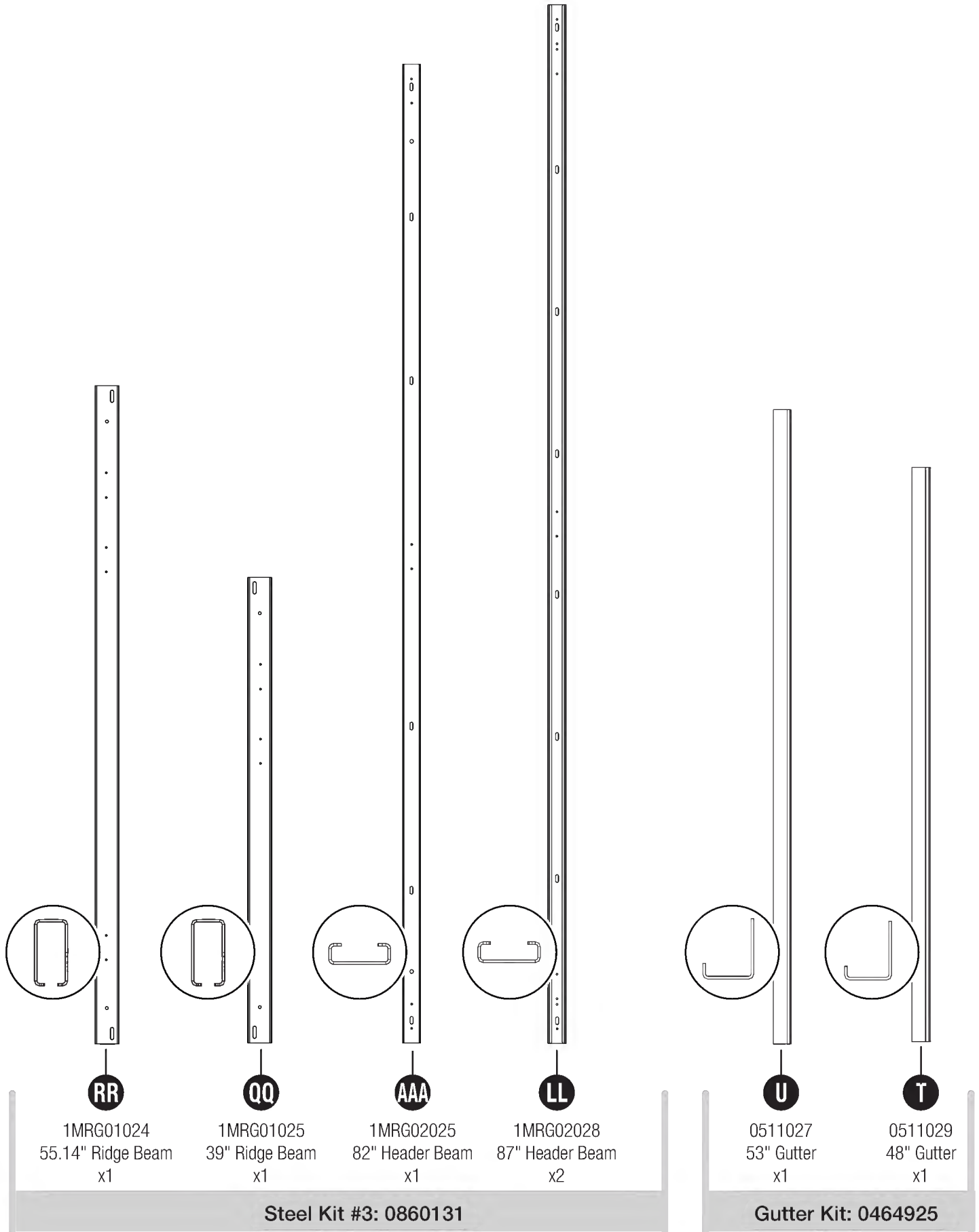

# Parts - Components

Parts Box: 0464867

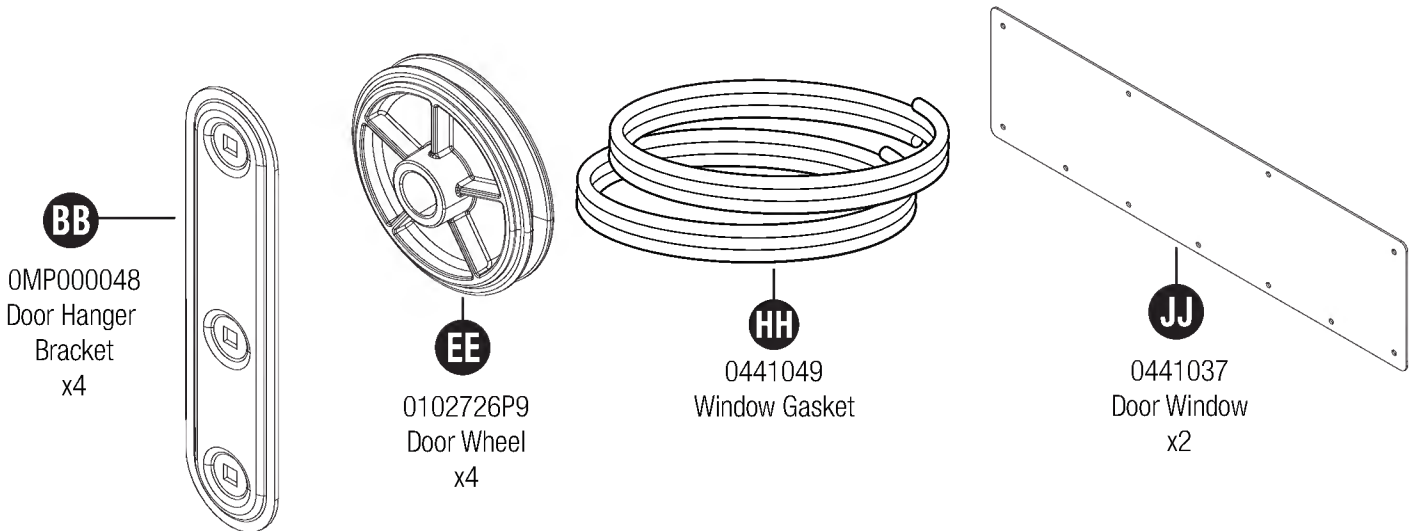
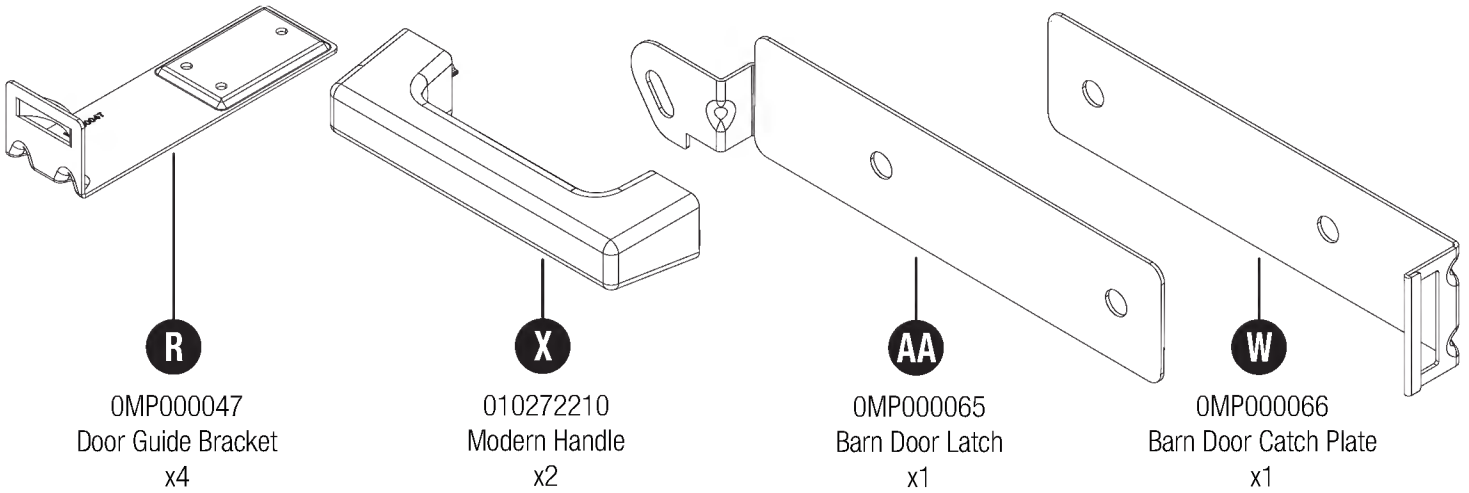

## 0480589 – Easy Driver & Slide

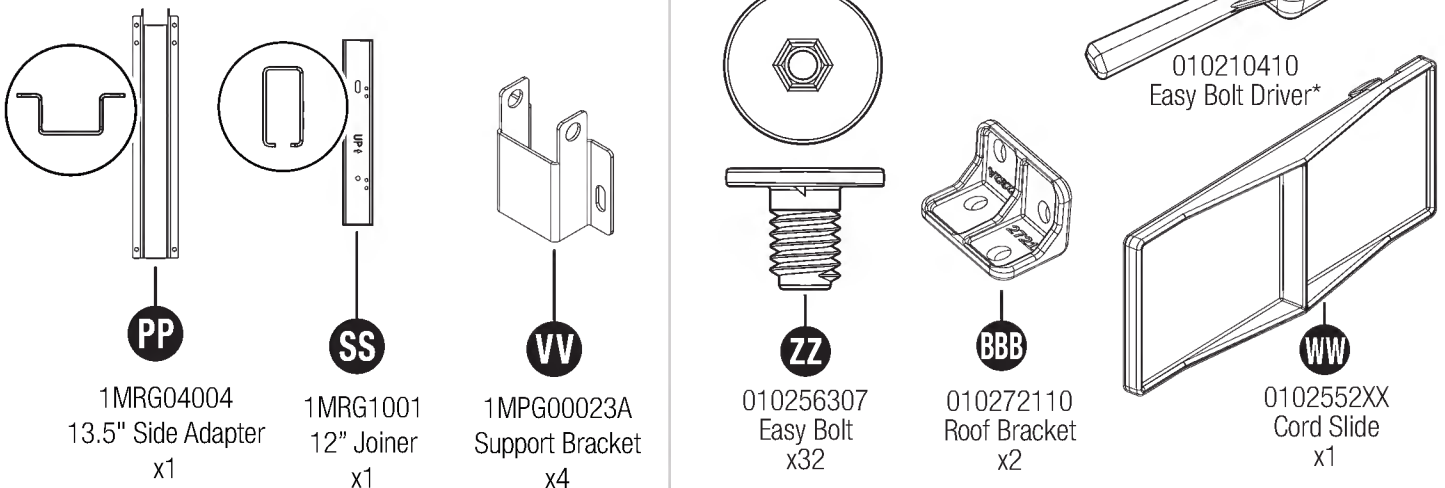



# Master Hardware Bag: 0470002

## Master Hardware Bag: 0470002

### 0480377 – #10 Screw (x2 bags)

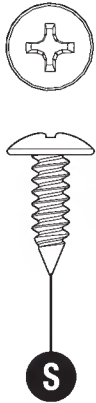

0630821  
#10 x .625"  
Screw  
x312  
(156 per bag)

### 0671319 – Barn Door

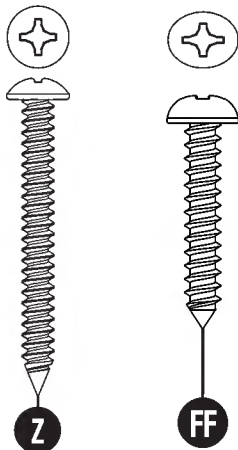

0632130  
#10 x 1.75"  
Screw  
x1

0631252  
#10 x 1"  
Screw  
x3

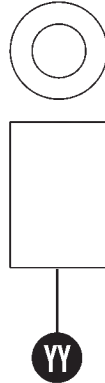

0510987  
Nylon Spacer  
x1

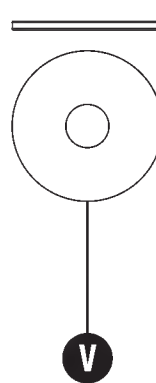

0631733A  
.25"  
Flat Washer  
x4

### 0671336 – Track



0631456  
1/4-20 x 1.5"  
Carriage Bolt  
x8

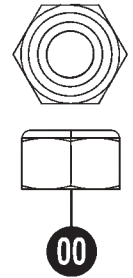

0631732  
.25-20 Lock Nut  
x8

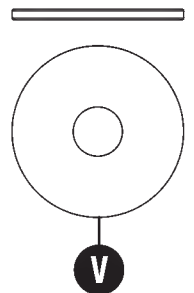

0631733A  
.25" Flat Washer  
x1

### 0671320 – Hanger



0632496  
1/4-20 x 1.25"  
Carriage Bolt  
x12



0510987  
Nylon Spacer  
x4

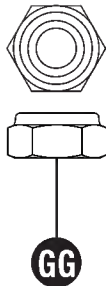

0631148  
.25"-20  
Nylon  
Lock Nut  
x12

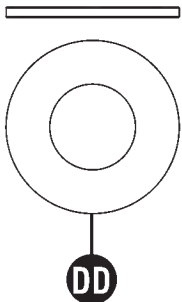

0631011  
.375" Flat Washer  
x4

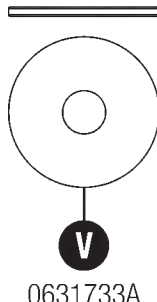

0631733A  
.25" Flat Washer  
x12

### 0671318 – Steel



0632504  
.25"-20 x 2"  
Hex Bolt  
x15

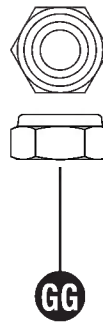

0631148  
.25"-20  
Nylon Lock-Nut  
x15

### 0671321 – Sliding Door

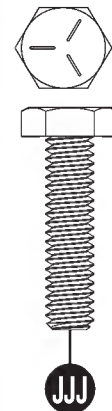

0631115  
.25-20 x 1"  
Hex Bolt  
x2

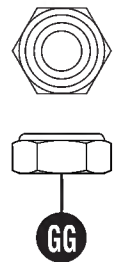

0631148  
.25-20  
Lock Nut  
x2

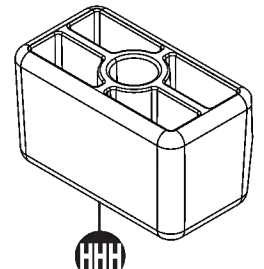

0102748P9  
Door Bumper  
x2

# Parts: Accessories

Please note, not all shed models include accessories.

Please reference the UPC located on the shed packaging to determine your shed's model number.



**BMS8780T**

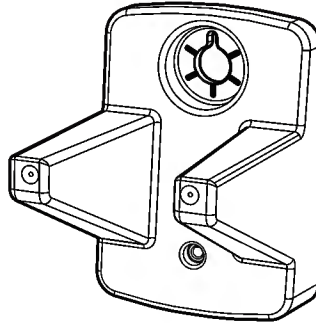

0102785P9  
Tool Hanger  
x4

Easy bolts required for mounting accessories included with shed hardware.

To view full range of accessories available for your shed, please visit our website at [www.suncast.com](http://www.suncast.com).

# Site Preparation and Platform Construction

Materials **NOT** supplied with Shed Kit

## Important:

- **Site preparation is required for this shed. Placing the shed on a properly constructed, square, flat, smooth and level foundation, as described below, is required. Without a properly constructed foundation, settling will eventually occur, causing distortion and damage to the shed. Suncoast is not responsible for replacing parts damaged or property lost due to incorrect foundation construction or improper assembly. Warranty requires a properly constructed foundation to which the shed must be anchored as instructed below.**
- **Complete the site preparation and foundation construction before unpacking parts and beginning assembly. For tips on site preparation, go to [www.suncoast.com](http://www.suncoast.com), consult retailer, or local code.**

## Site Preparation

1. Consult your local authorities for building codes and covenants before beginning foundation or erecting shed.
2. Before any digging, check with local utilities to determine location of buried cables, pipes, etc.
3. Decide which type of foundation is most suitable for your installation. The foundation surface must be square, flat, smooth and level. Follow the below guidelines for foundation options.
4. Complete the foundation preparations as follows:
  - A vapor barrier may be applied over the foundation to prevent excessive condensation in the shed. Follow local building codes for a proper vapor barrier.
  - The ground should slope away from the foundation area to provide drainage.
  - Placing the shed on surfaces made of materials such as patio blocks or pavers is not acceptable for long-term support structure or smooth surface. Use of these will void the warranty.

### Concrete Slab

- Construct a slab of at least 4" thickness.
- The use of reinforcement bar is recommended.
- For foundations larger than specified below, the shed must rest on a continuous, level portion of the concrete slab.

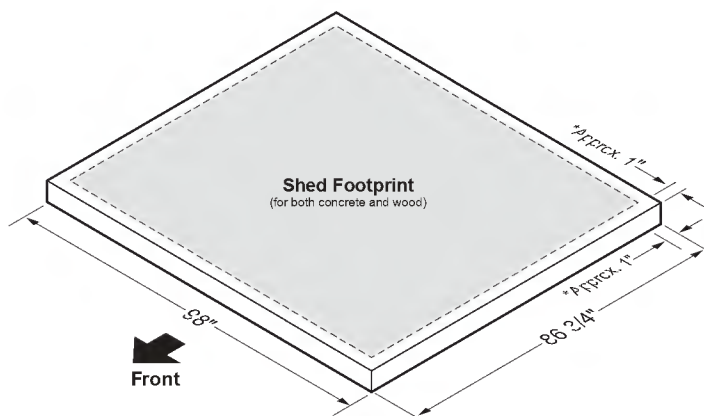

### Wood Platform

- Use exterior grade wood.
- Set the wood platform on deck footing blocks or full footing.

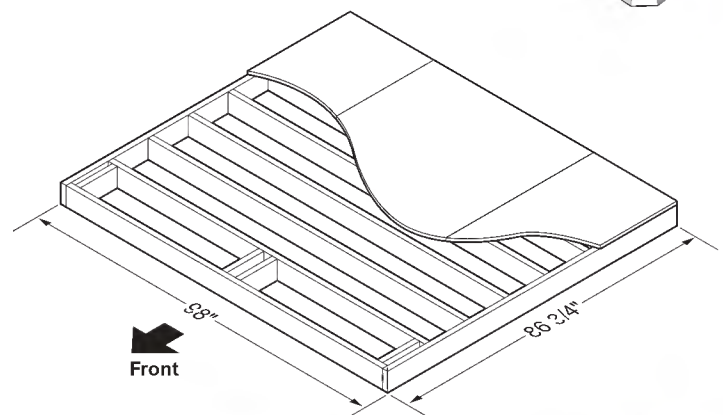
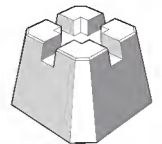

\* Dimensions shown are minimal for proper fit of the shed.

### **Anchoring the Floor Panels to the Foundation is required after shed assembly is complete.**

- Shed floor panels include wall anchor locations as well as flattened areas where anchors or lag screws are to be secured. These flat areas must be drilled through prior to securing the floor panels to the foundation.
- The shed must be secured to a continuous concrete slab using 3/8" masonry anchors with 1" washers (hardware not included). **8 masonry anchors are required.**

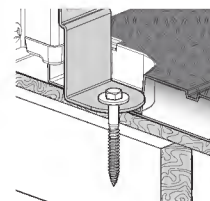

Wall anchor section example

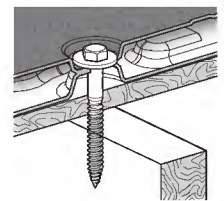

Floor anchor section example

- The shed must be secured to a wood platform using 1/4"-3/8" x 3" lag screws with 1" washers (hardware not included). **8 lag screws are required.**

**Note:** Shed floor fastening locations are designed to align with the under-structure layout. Be sure the front of the floor panels are oriented correctly on the platform to ensure lag bolts engage with the under-structure.

# Site Preparation and Platform Construction (continued)

Materials NOT supplied with Shed Kit

## Wood platform critical spacing

- Check all critical spacing measurements carefully.

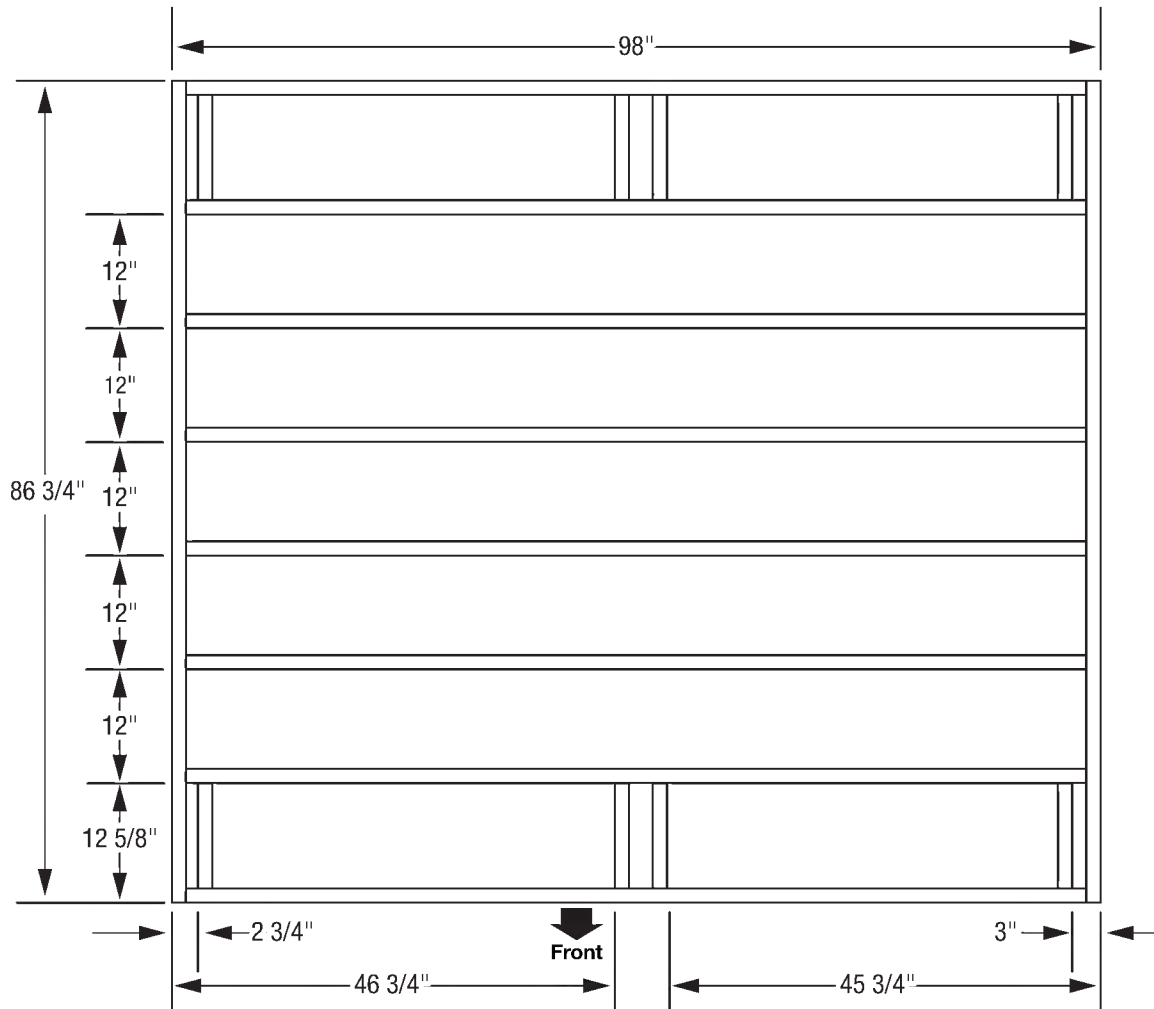

## Wood platform materials list

Item	Qty	Size
a	1	48" x 86.75" x .75"
b	2	25" x 86.75" x .75"
c	8	2" x 6" x 11.125"
d	2	2" x 6" x 86.75"
e	8	2" x 6" x 95"

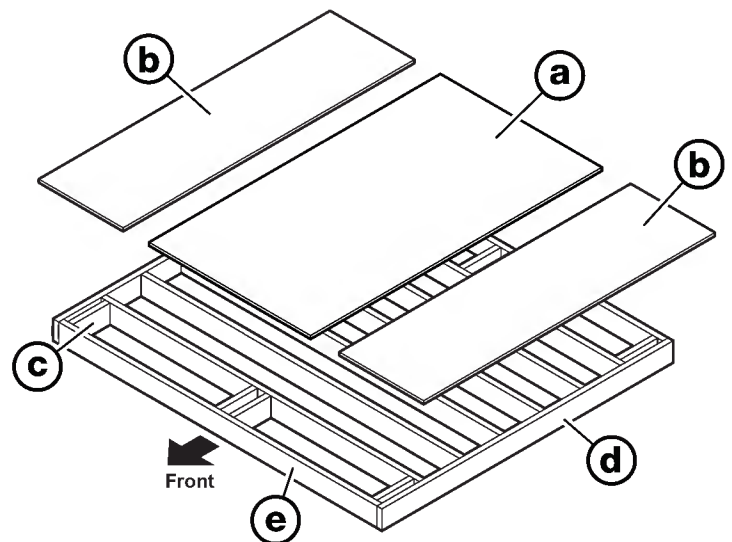

- Please note, 2 x 6 dimensional lumber is actually 1/2" smaller than noted sizes. Dimensions given presume standard 1.5" x 5.5" actual size lumber. Lumber dimensions can vary. Check lumber dimensions before cutting and make appropriate adjustments to achieve given dimensions. Cut sizes are actual size.

**IMPORTANT:** If you choose to use a power drill to assemble the product, refer to caution statements for power drill guidelines. Damage to parts due to over-torque are not covered under Suncoast's limited-warranty. This item uses self-tapping screws in some areas. There are no pre-drilled holes. Some pressure may be needed when starting to drive the screw. Once the screw pierces the plastic it will drive easier.

## Pre-Assembly - Floor Guides

### Required Hardware/ Steel Kits

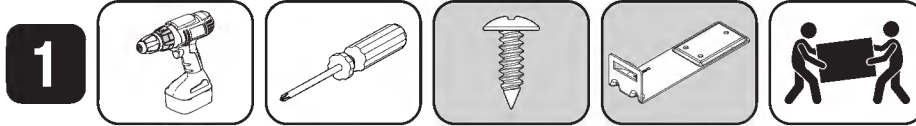

(S) x12

(R) x4

Stand the right floor (B) horizontal. From the bottom of the panel, install 2 door guide brackets (R) and secure with 3 screws (S) each as shown.

Repeat for left floor (A).

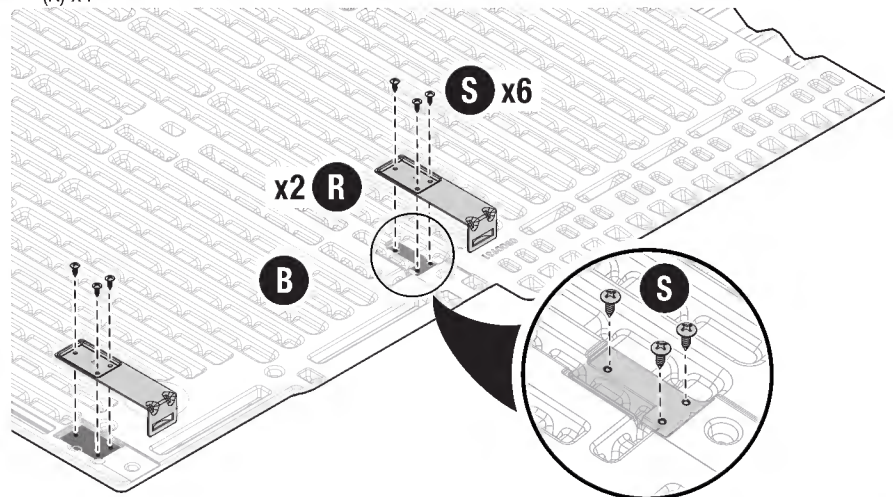

## Pre-Assembly - Door Handles

### Required Hardware/ Steel Kits

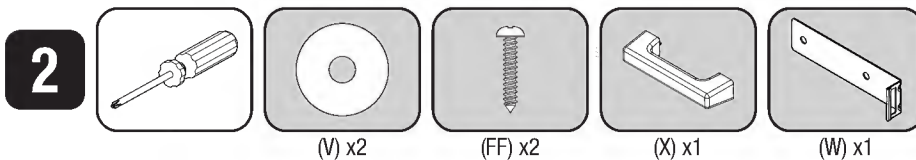

(V) x2

(FF) x2

(X) x1

(W) x1

From the inside of the left door (L) install 2 washers (V) and 2 screws (FF). From the outside of the door place door catch plate (W) and 1 door handle (X) through the previously installed screws (FF). Tighten securely.

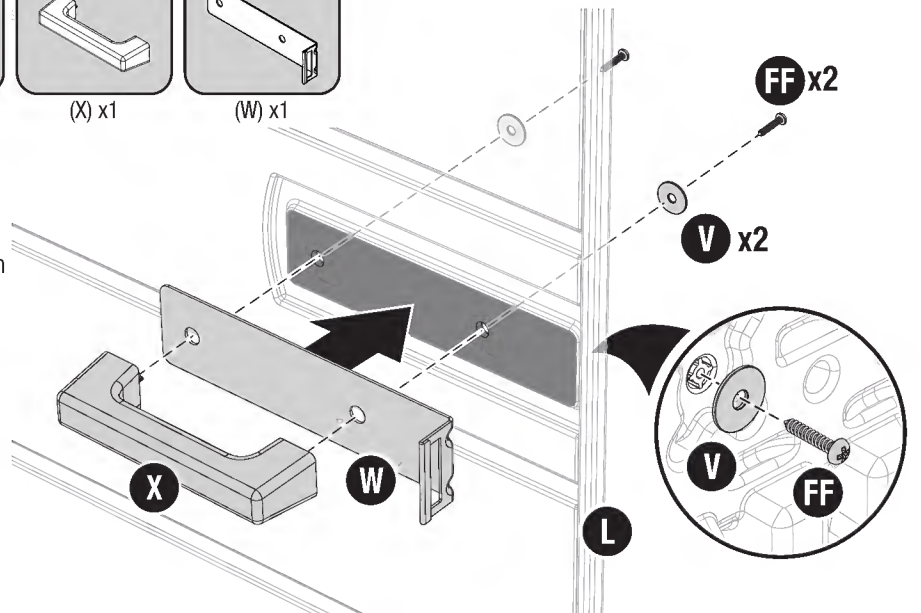

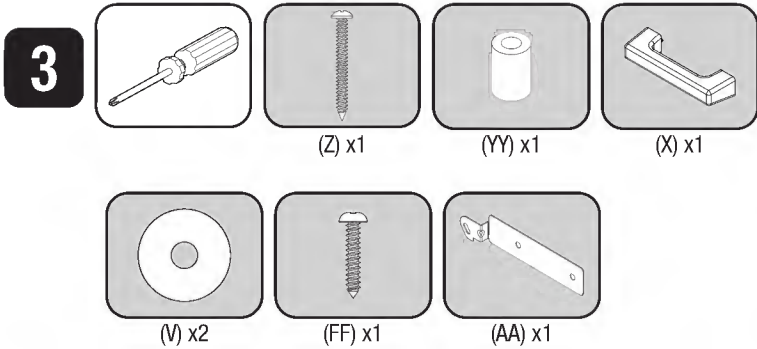

From the inside of the right door (D) install washer (V), nylon spacer (YY), and screw (Z) through the slotted hole.

Install 1 washer (V) and 1 screw (FF) in the remaining hole.

From the outside of the door (D), place door latch (AA) and 1 door handle (X) through the previously installed screws as shown. Proceed to thread screws (FF,Z) into the handle (X).

Do not overtighten, handle should move freely.

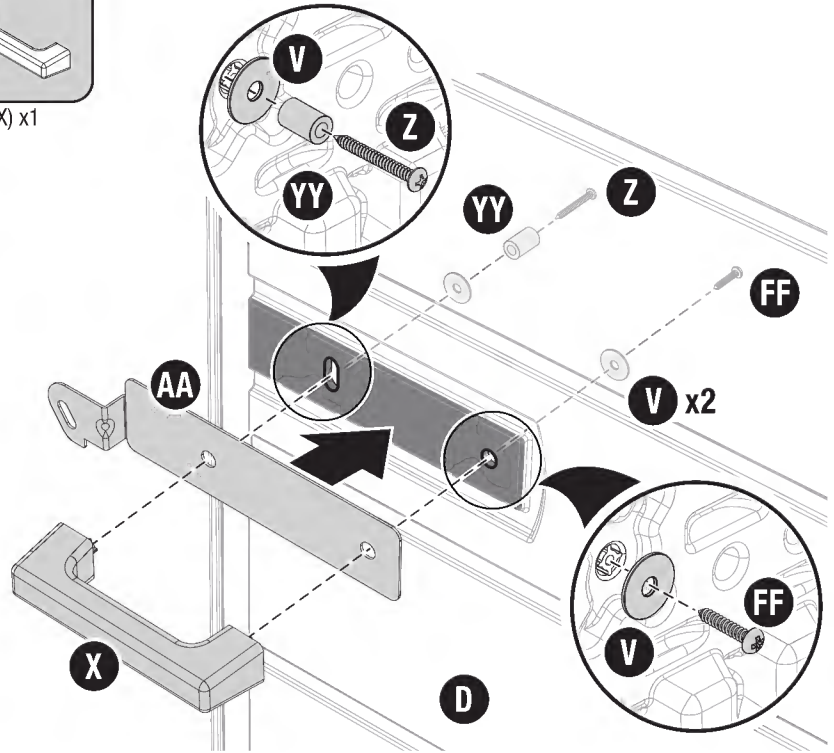

## Pre-Assembly - Door Hangers

### Required Hardware/ Steel Kits

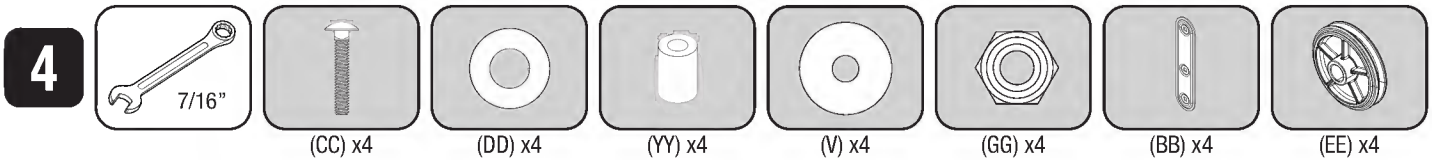

Orient 1 door hanger bracket (BB) as shown. Place 1 bolt (CC) through top hole and install the following parts in order: 1 washer (DD), 1 nylon spacer (YY), 1 door track wheel (EE), and 1 larger washer (V) secure with 1 lock nut (GG).

**IMPORTANT:** Refer to images provided for proper orientation. Do not overtighten, wheel should spin freely.

Repeat for remaining 3 door hanger assemblies.

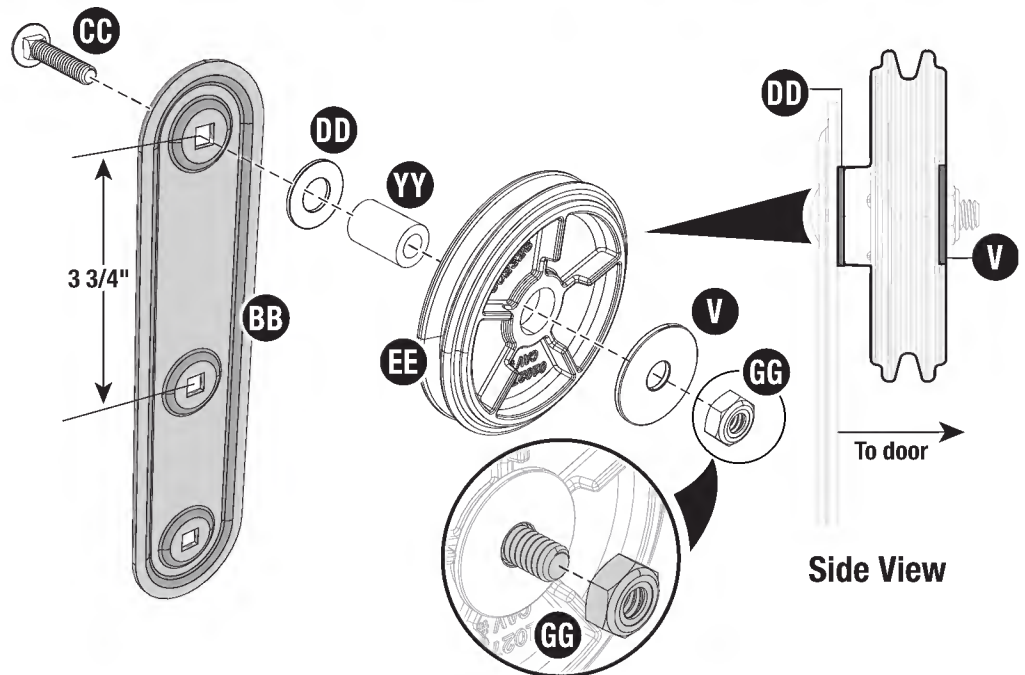

5

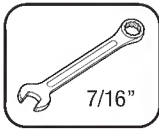

7/16"

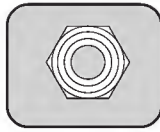

(GG) x8



(CC) x8

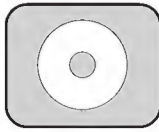

(V) x8

**NOTE:** The 2 holes in both door panel pockets may need to be pierced prior to inserting bolts.

Tilt the left door (**L**) upright. Nest door hanger assembly into the pocket of left door as shown. Secure with 2 bolts (**CC**), 2 washers (**V**), and 2 locknuts (**GG**).

**Repeat** to install second door hanger assembly on left door and remaining door assemblies on right door (**D**).

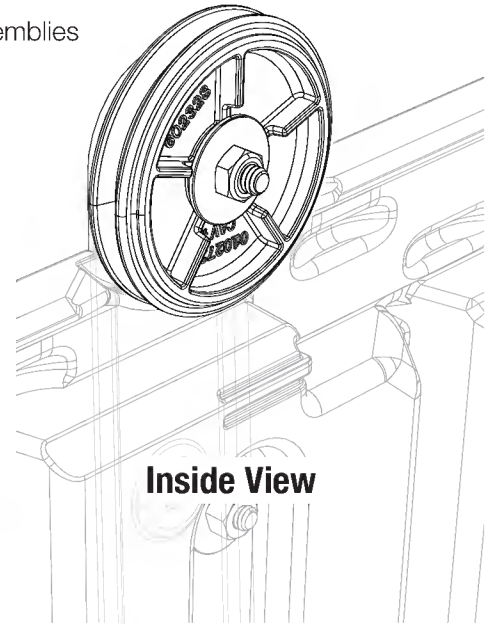
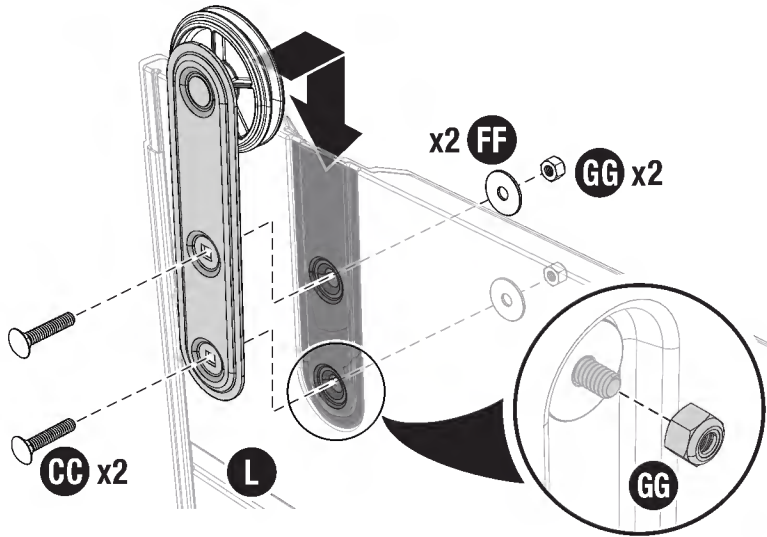

## Pre-Assembly - Windows

### Required Hardware/ Steel Kits



0480377

6

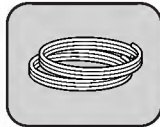

(HH)

Place left header (**Q**) with smooth side facing down on a flat surface. Starting at the top-center, working clockwise press 1 gasket (**HH**) into channel as shown. Trim any excess gasket with scissors. **Repeat** for right header (**M**).

**NOTE:** Do not stretch the gasket when installing. Press firmly downward and slightly backward while running the gasket around the gasket channel.

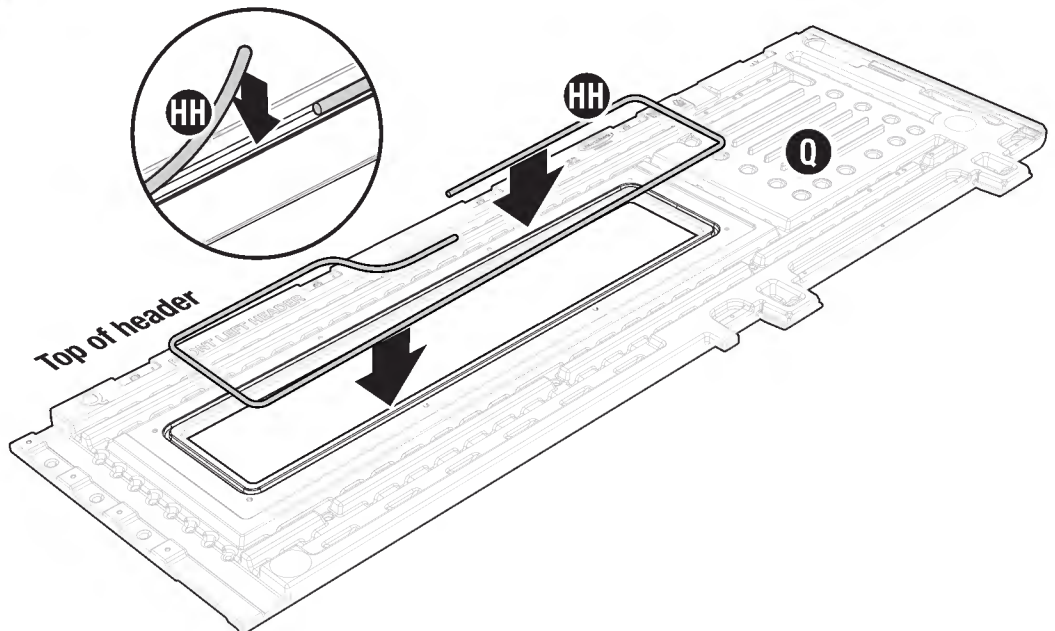

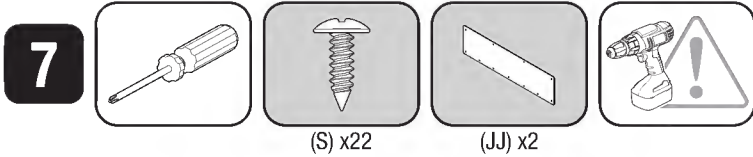

Starting with left header (Q) install window (JJ) as shown and secure with 11 screws (S). Do not overtighten. Repeat for right header (M).

**NOTE:** Remove the protective film from both sides of the window (JJ) prior to installation.

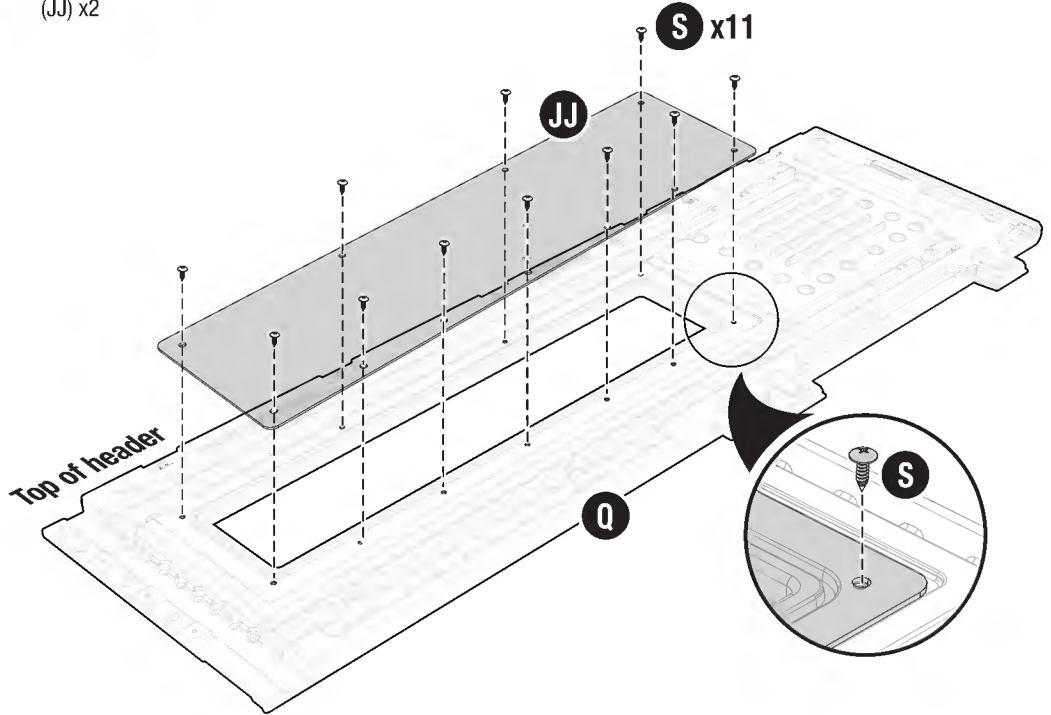
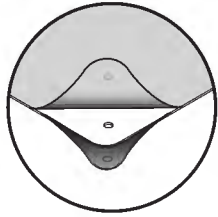

## Pre-Assembly - Header

### Required Hardware/ Steel Kits

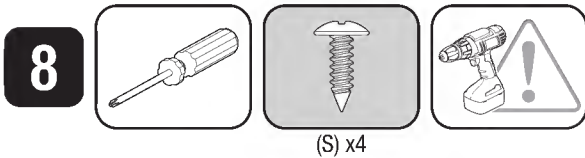

Place right front header (M) into slot on left front header (Q) as shown and secure with 4 screws (S).

**IMPORTANT:** Make sure the bottom edges of both headers are flush. Do not overtighten.

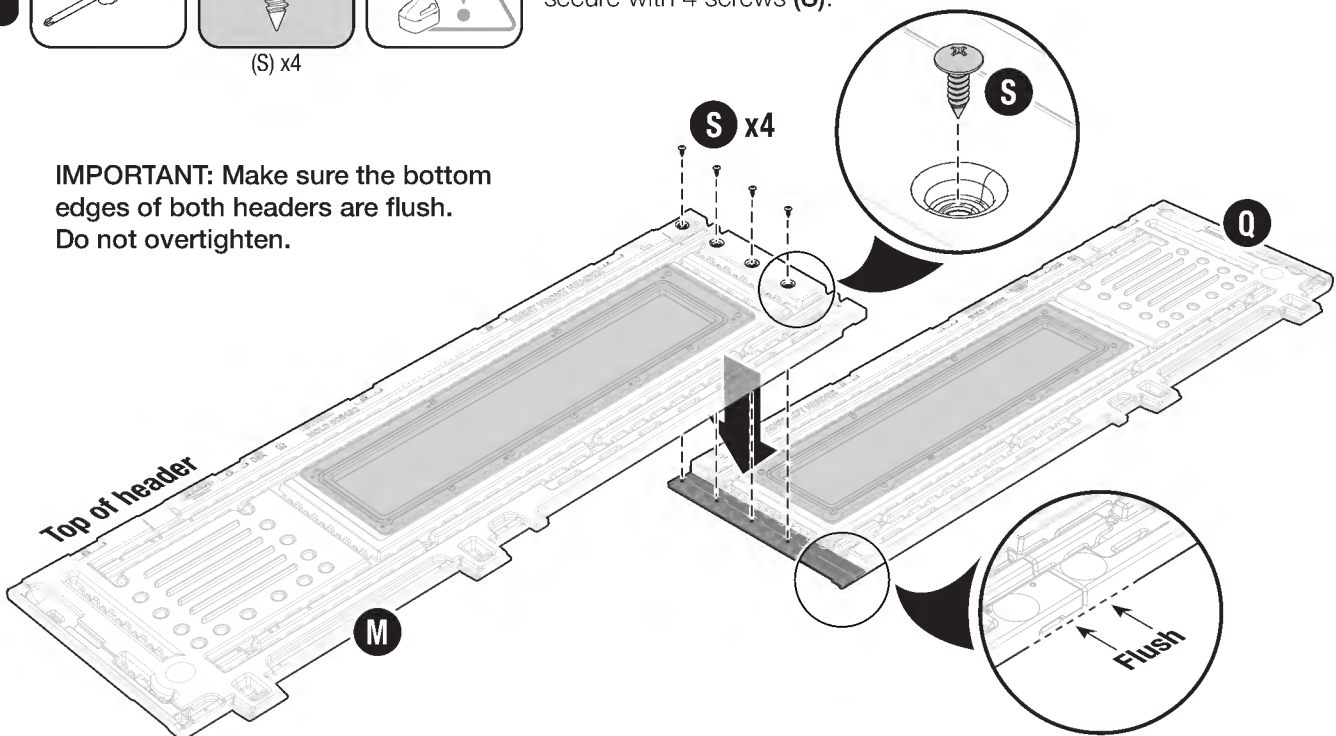



9

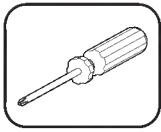

(S) x12

Place 2 header beams (87",LL) in channels of headers (M,Q). Secure header beams (LL) with 12 screws (S).

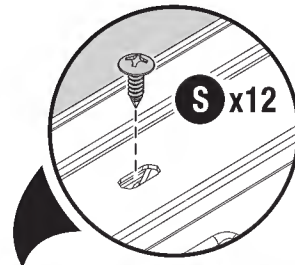

Top of header

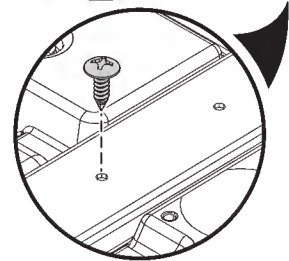
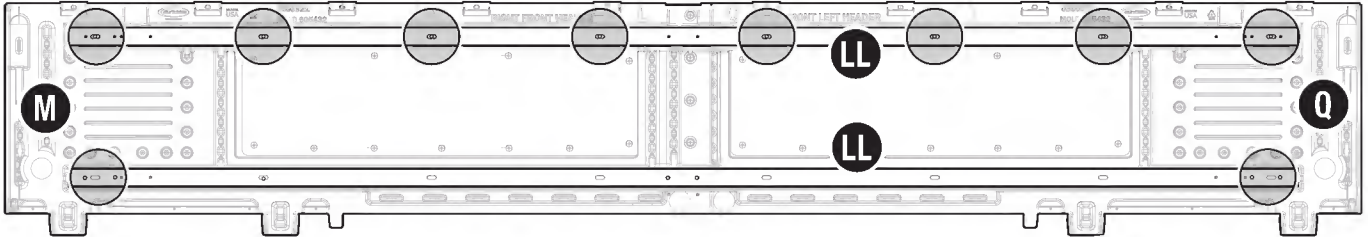

**IMPORTANT:** Pay particular attention to the screw locations indicated in the images. Install screws into exact locations as shown (not all screw holes are used at this point in the assembly). The slotted holes will be used on the top of the header beam, while the circular holes will be used on the bottom of the header beam.

10

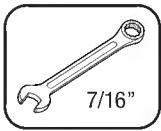

7/16"



(NN) x8

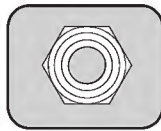

(OO) x8

**NOTE:** A screwdriver may be needed to pierce the holes on header prior to installing the carriage bolts.

Carefully, flip over header assembly (Q,M) so the smooth side is facing up. Nest 2 door tracks (MM) into pockets making sure that door tracks are aligned at center. Secure with 8 carriage bolts (NN) and 8 nuts (OO). Leave bolts loose as this time.

Top of header

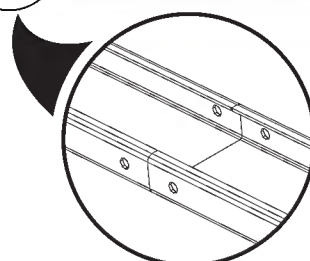
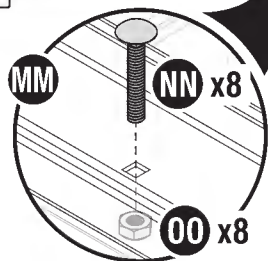
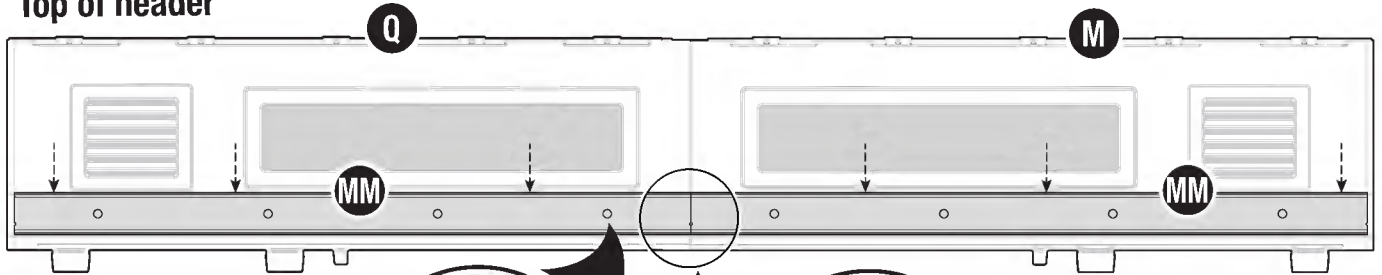

# Pre-Assembly - Side Adapter

## Required Hardware/ Steel Kits



11

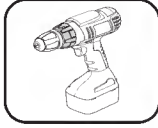
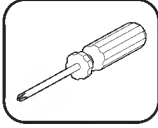

(S) x2

Carefully flip over header assembly (M,Q) so smooth side is facing down. Place side adapter (13.5",PP) as shown. Secure the top of the side adapter (PP) with 2 screws (S).

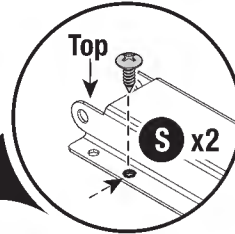

**IMPORTANT:** Orientation of side adapter (PP) is critical.

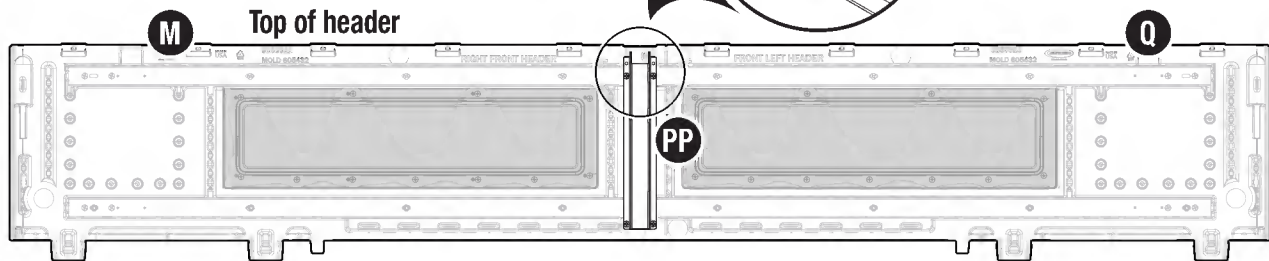

12

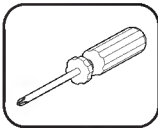

(S) x4

From the bottom of the header assembly (M,Q) slide the gutter (48",T) into position. Using 4 screws, secure gutter (T) at the locations indicated. **IMPORTANT:** The two middle screw locations will also secure the bottom of side adapter (PP).

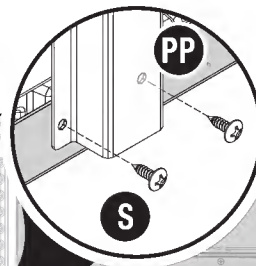

Top of header

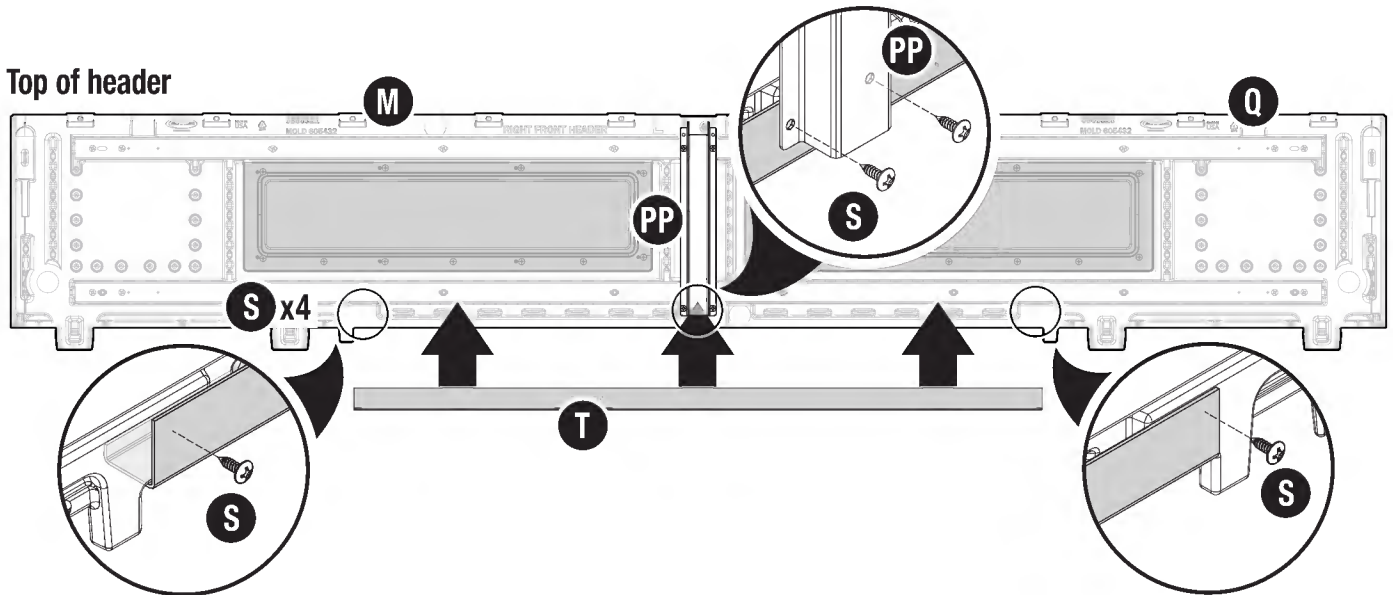

# Pre-Assembly - Cord Slide

## Required Hardware/ Steel Kits



13

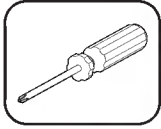

(S) x1

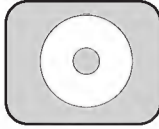

(V) x1

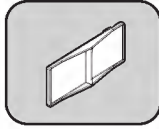

(WW) x1

Attach the cord slide (WW) to the left back panel (I) using 1 screw (S) and washer (V).

**NOTE:** Do not overtighten the screw. The cord slide should easily slide back and forth without much resistance.

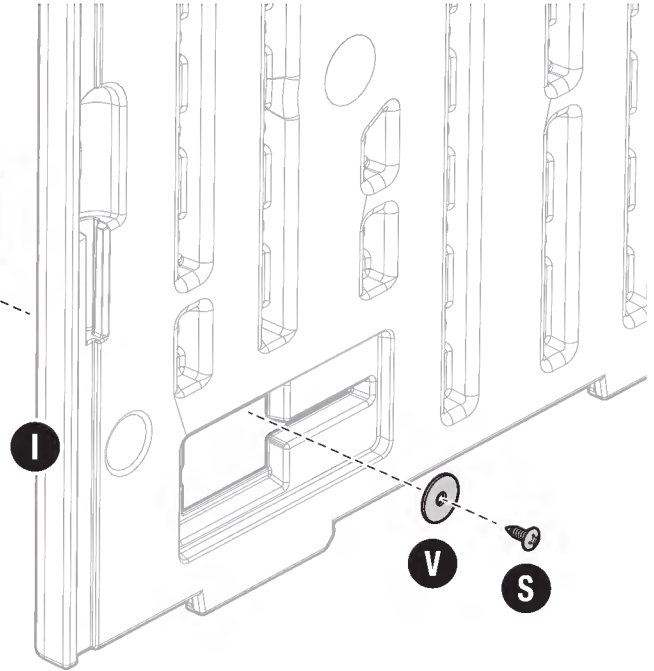
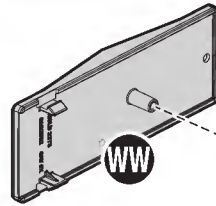

# Assembly - Floor

## Required Hardware/ Steel Kits



14

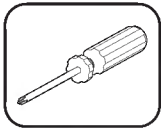

(S) x7

Slide the left and right floors (A,B) together. Secure with 7 screws (S).

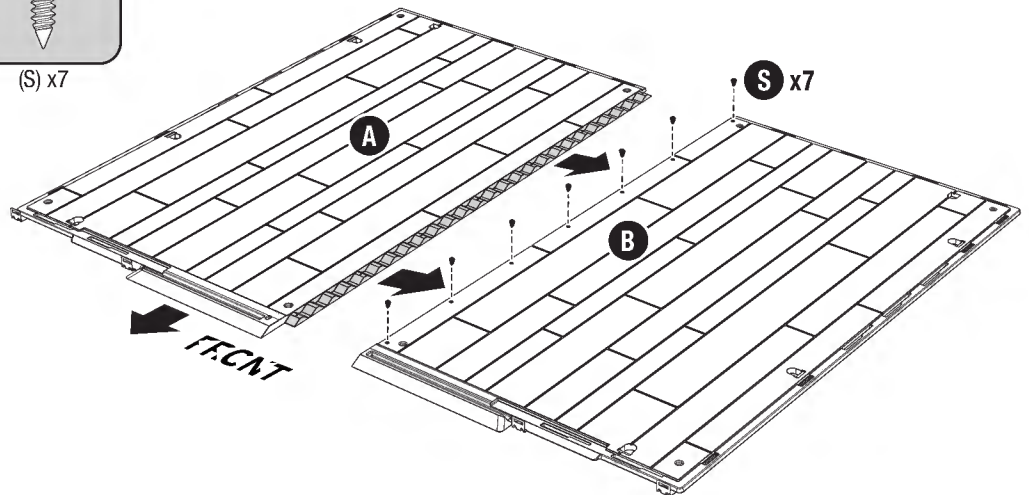

# Assembly - Walls

## Required Hardware/ Steel Kits

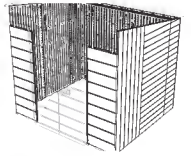

15



Insert the bottom tabs of left front (E) into the slots of the left floor (A) as shown. Slide the left front towards the center of the floor until it locks into place.

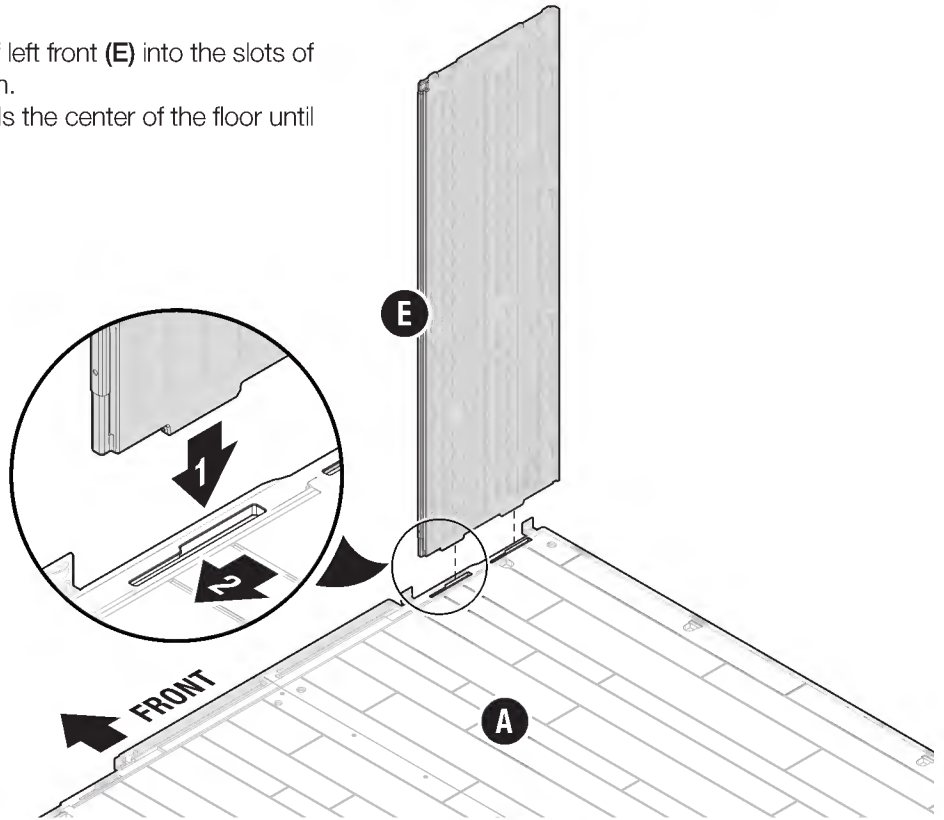

16



Align the side tabs of left front side (F) with the slots on left front (E). Slide left front side (F) down to engage tabs. Continue to press firmly until bottom tabs snap into left floor (A) as shown.

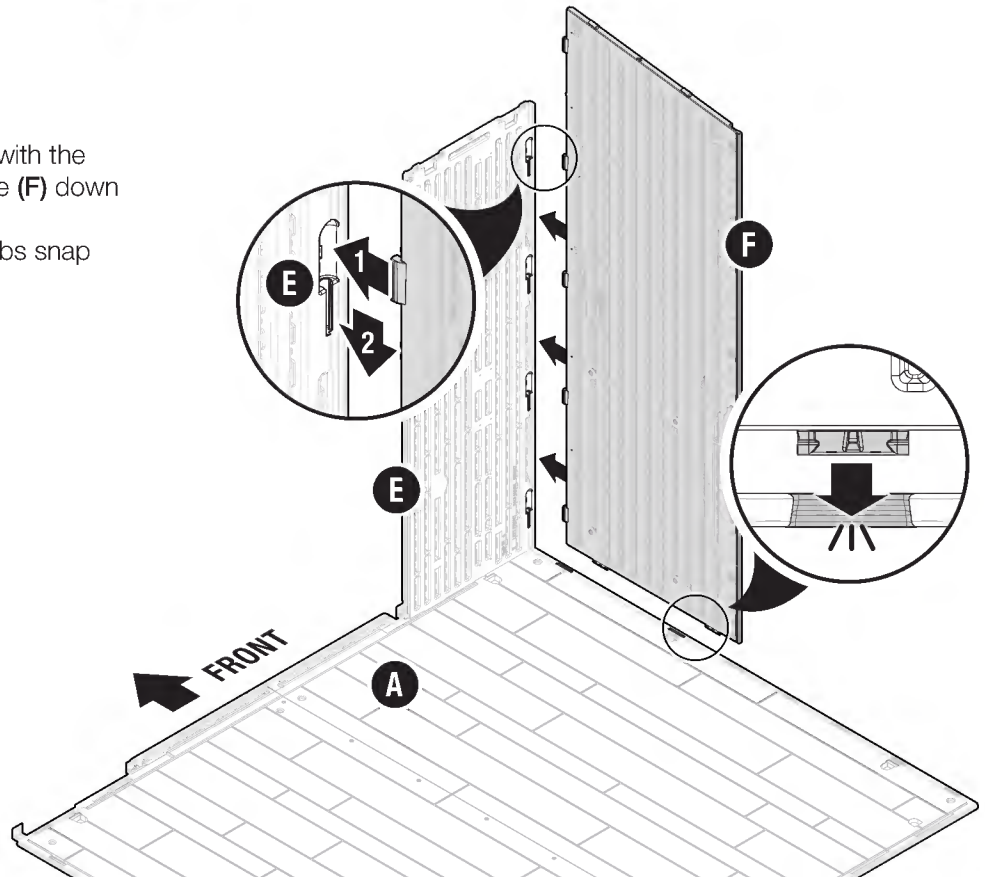

17



Insert the bottom tabs of left middle side (**G**) into the slots of the left floor (**A**) as shown.

Slide the left middle side (**G**) towards the front of the floor until it locks into place.

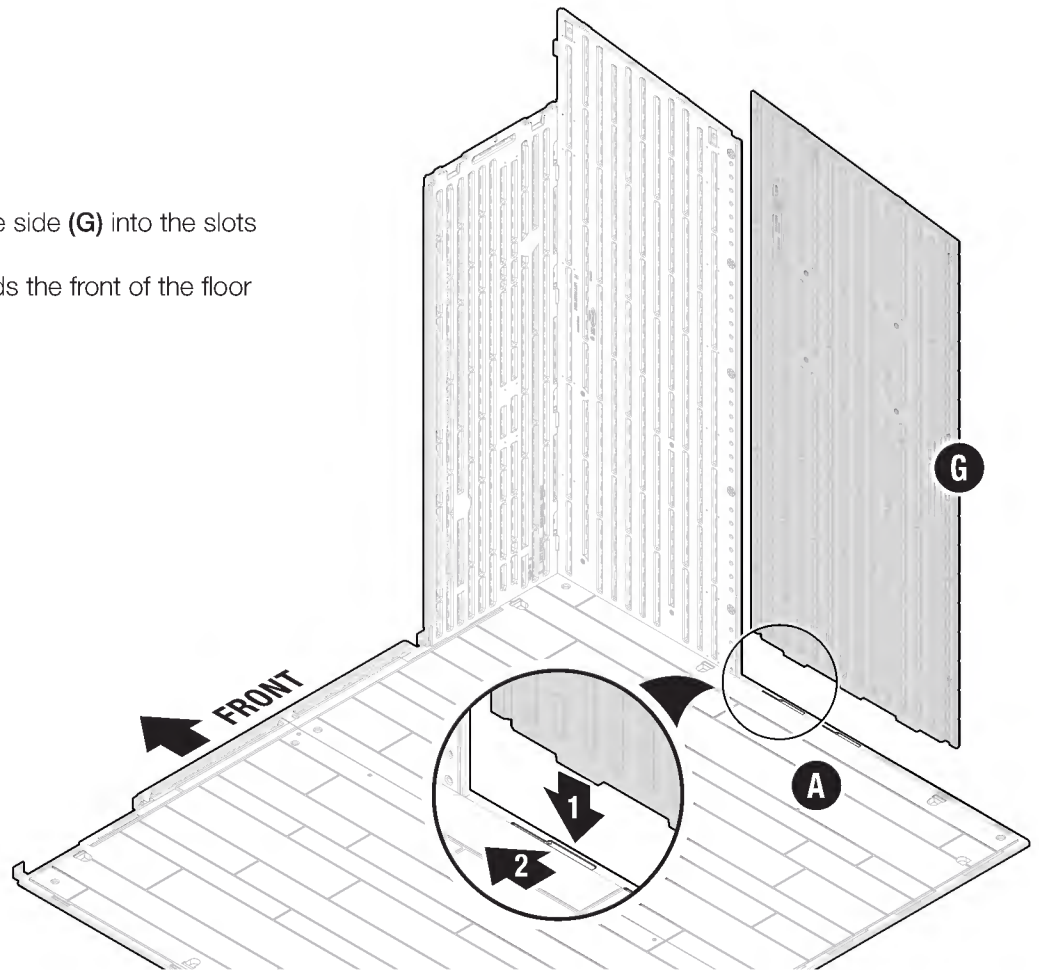

18

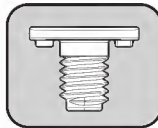
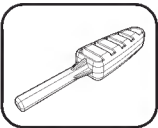

(ZZ) x5



Secure the left middle side (**G**) to the left front side (**F**) using 5 easy bolts (**ZZ**).

Tighten securely (3-4 clicks).

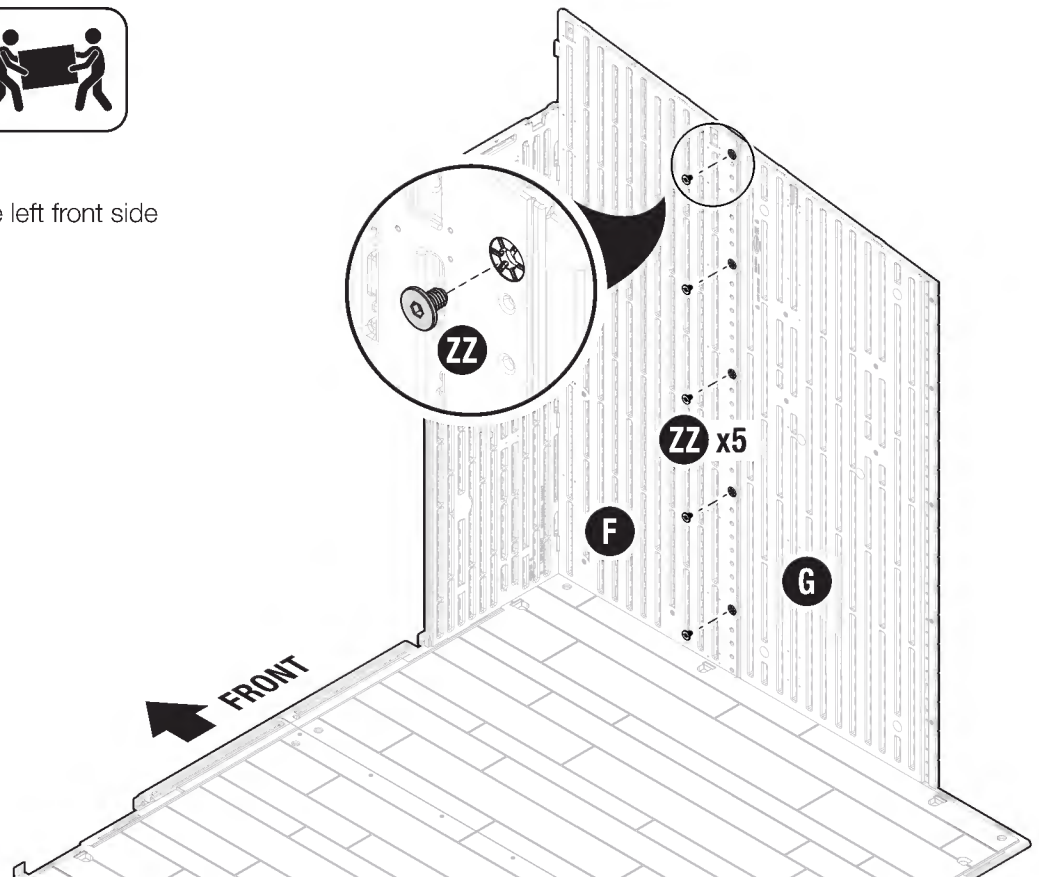



19

Insert the bottom tabs of the left back **(I)** with the slots of the left floor **(A)** as shown.  
Slide the left back **(I)** towards the corner of the floor (as indicated by the arrow) until it locks into place.

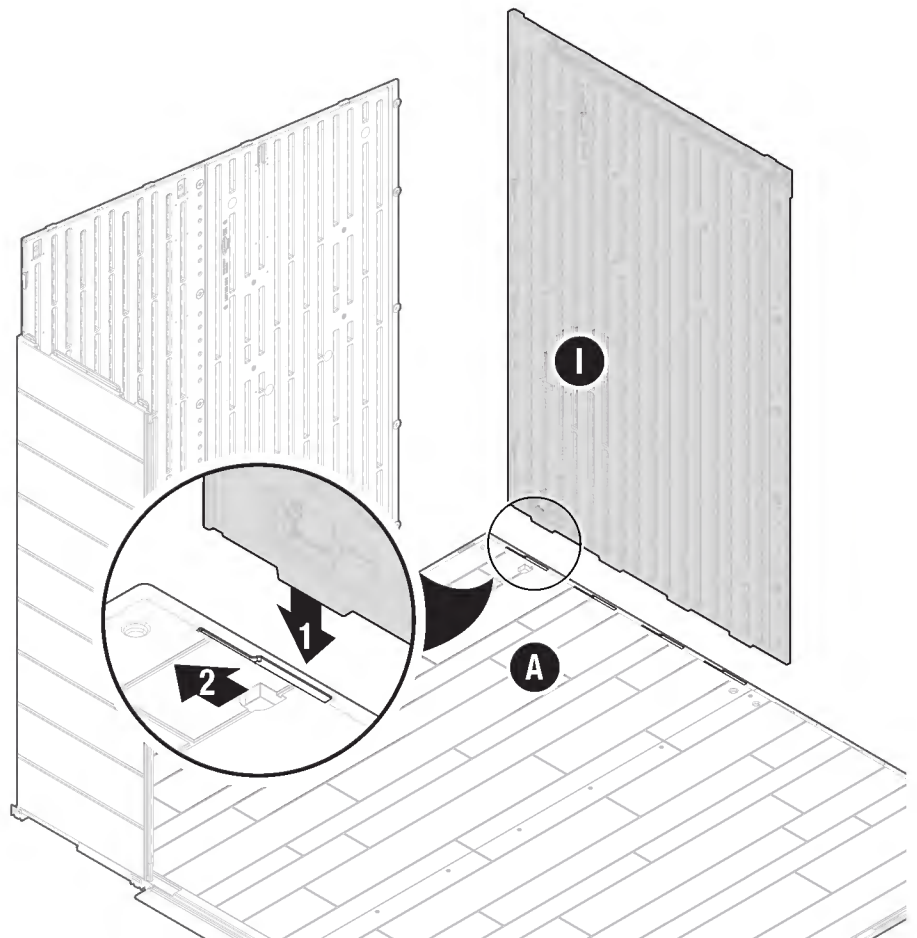

20

Align the side tabs of the left back side **(H)** with the slots on the left back **(I)**. Slide left back side **(H)** down to engage tabs.  
Continue to press firmly until bottom tabs snap into left floor **(A)** as shown.

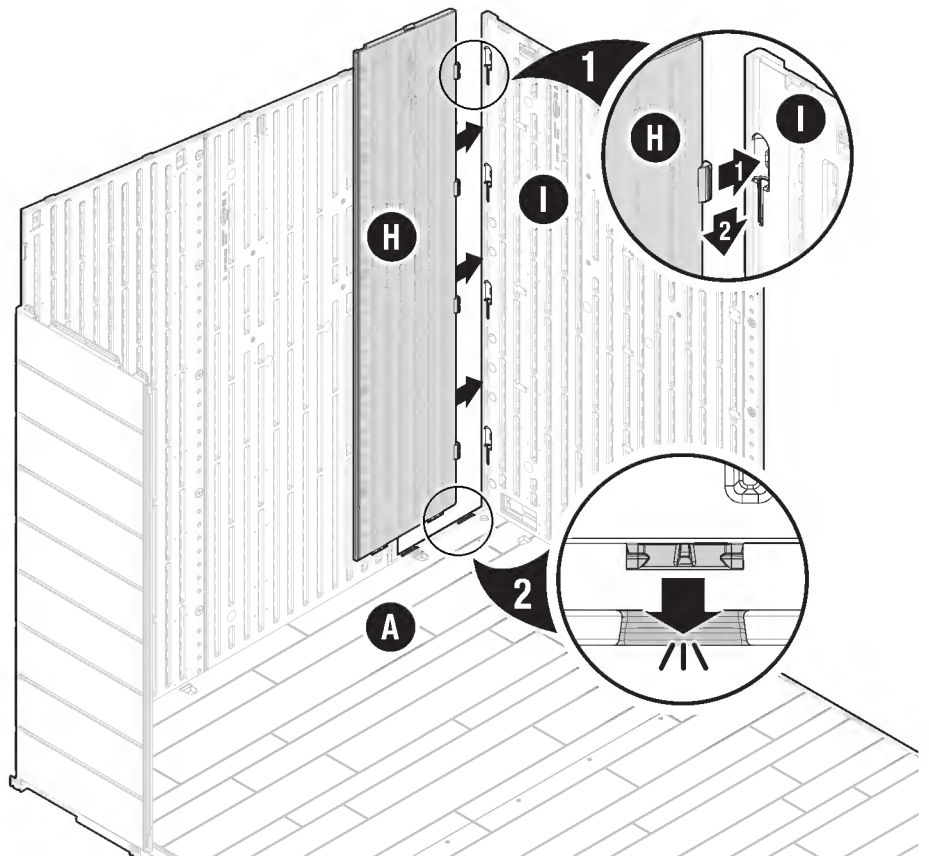

21

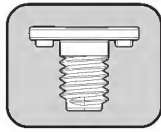
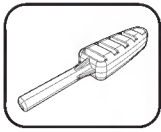

(ZZ) x5



Secure the left back side (**H**) to the left middle side (**G**) using 5 easy bolts (**ZZ**).  
Tighten securely (3-4 clicks).

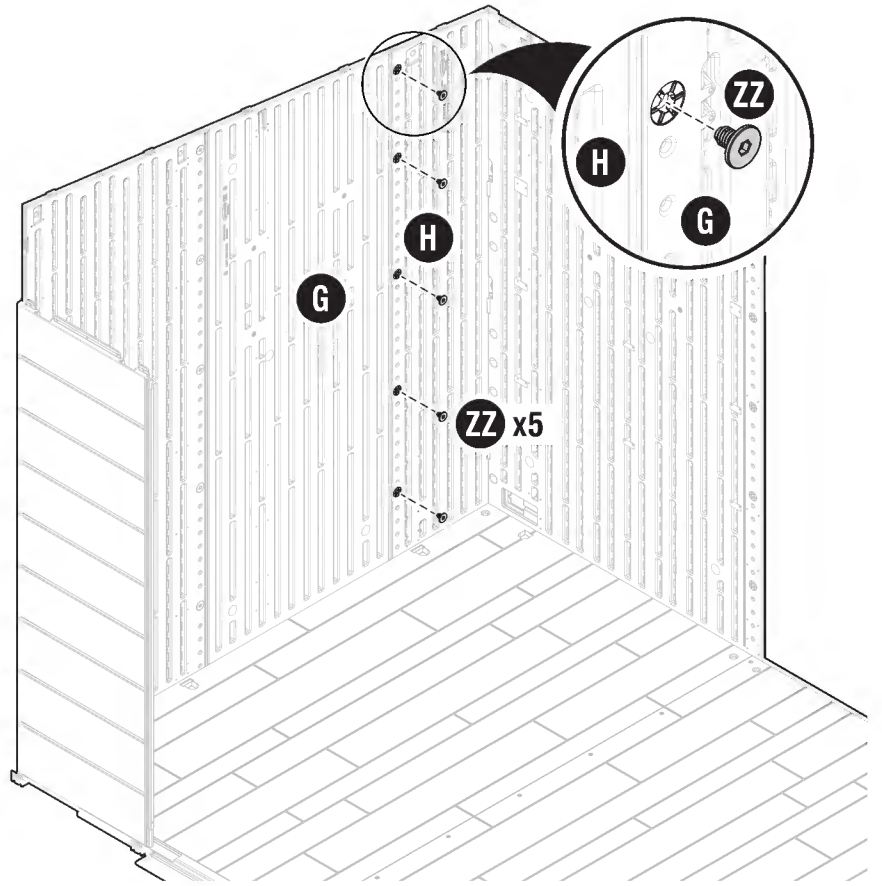

22



Insert the bottom tabs of right back (**J**) into the slots of the right floor (**B**) as shown.  
Slide the right back (**J**) towards the center of the floor until it locks into place.

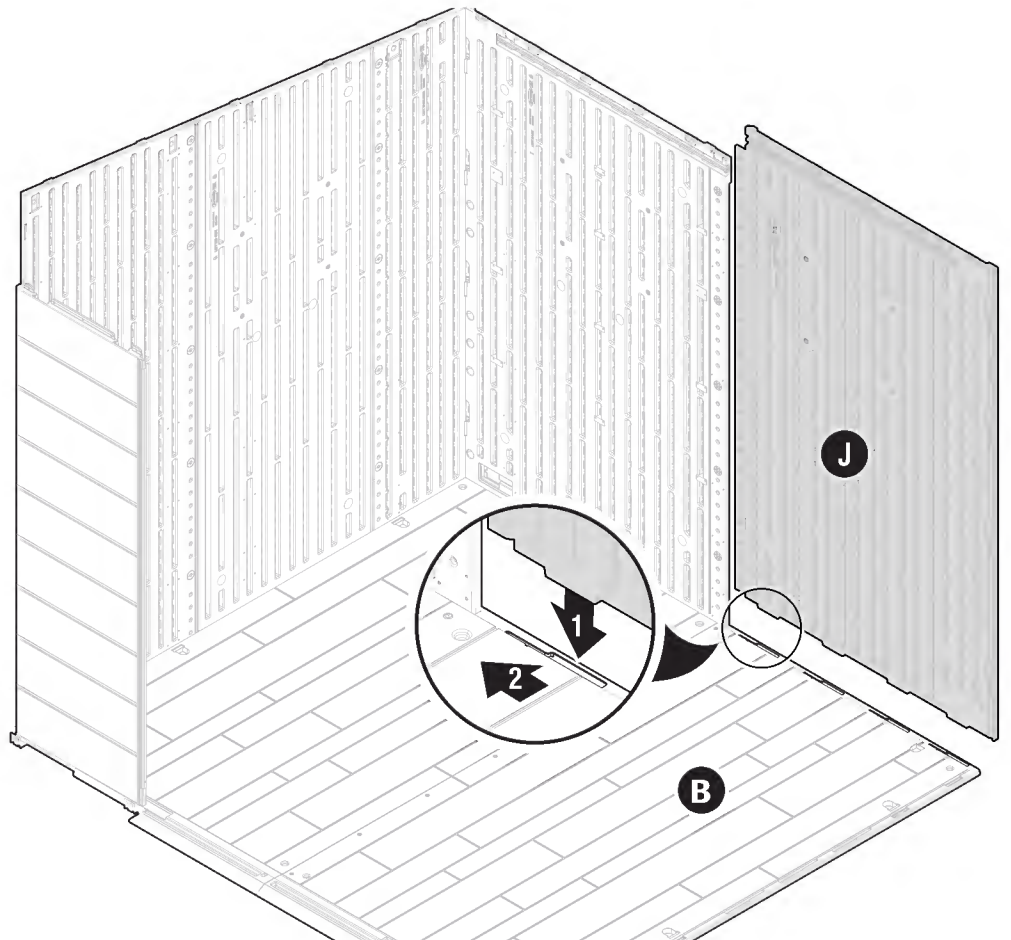

23

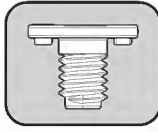
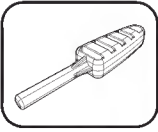

(ZZ) x5

Secure the left back (I) to the right back (J) using 5 easy bolts (ZZ). Tighten securely (3-4 clicks).

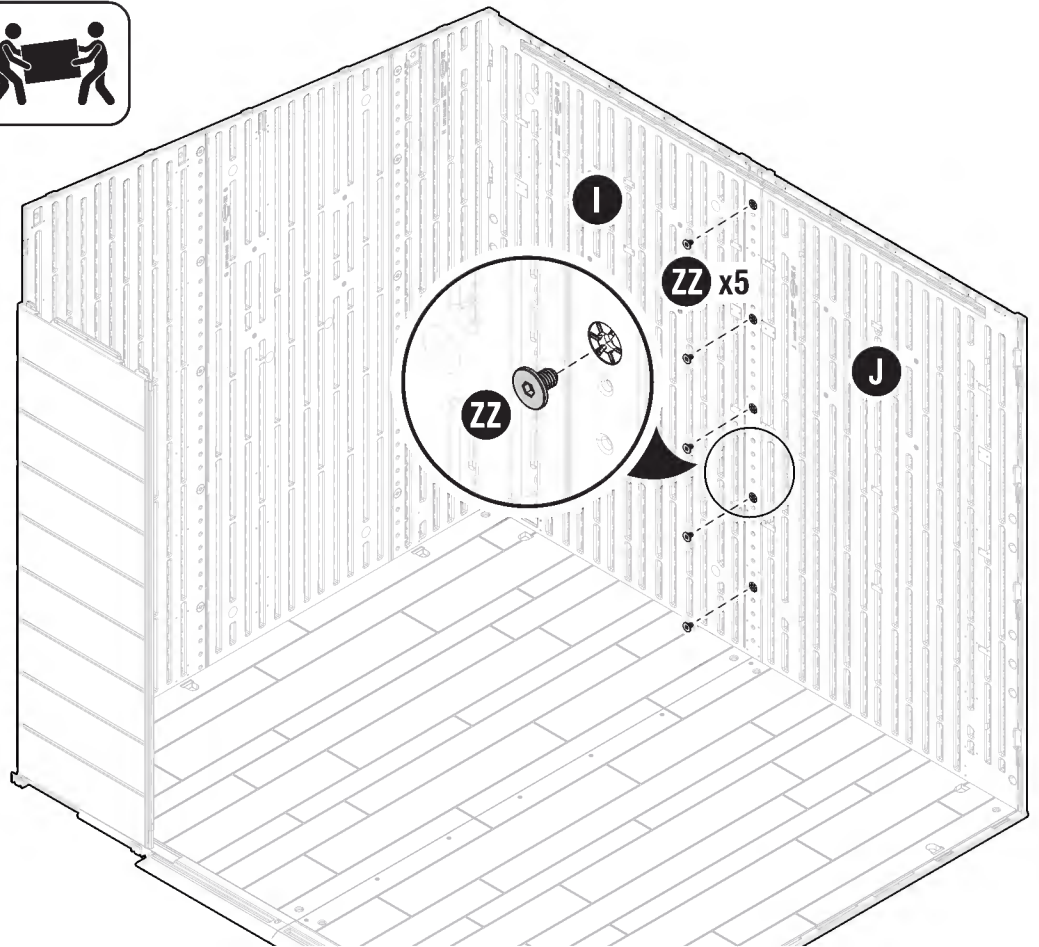

24



Align the side tabs of the right back side (K) with the slots on the right back (J). Slide right back side (K) down to engage tabs. Continue to press firmly until bottom tabs snap into right floor (B) as shown.

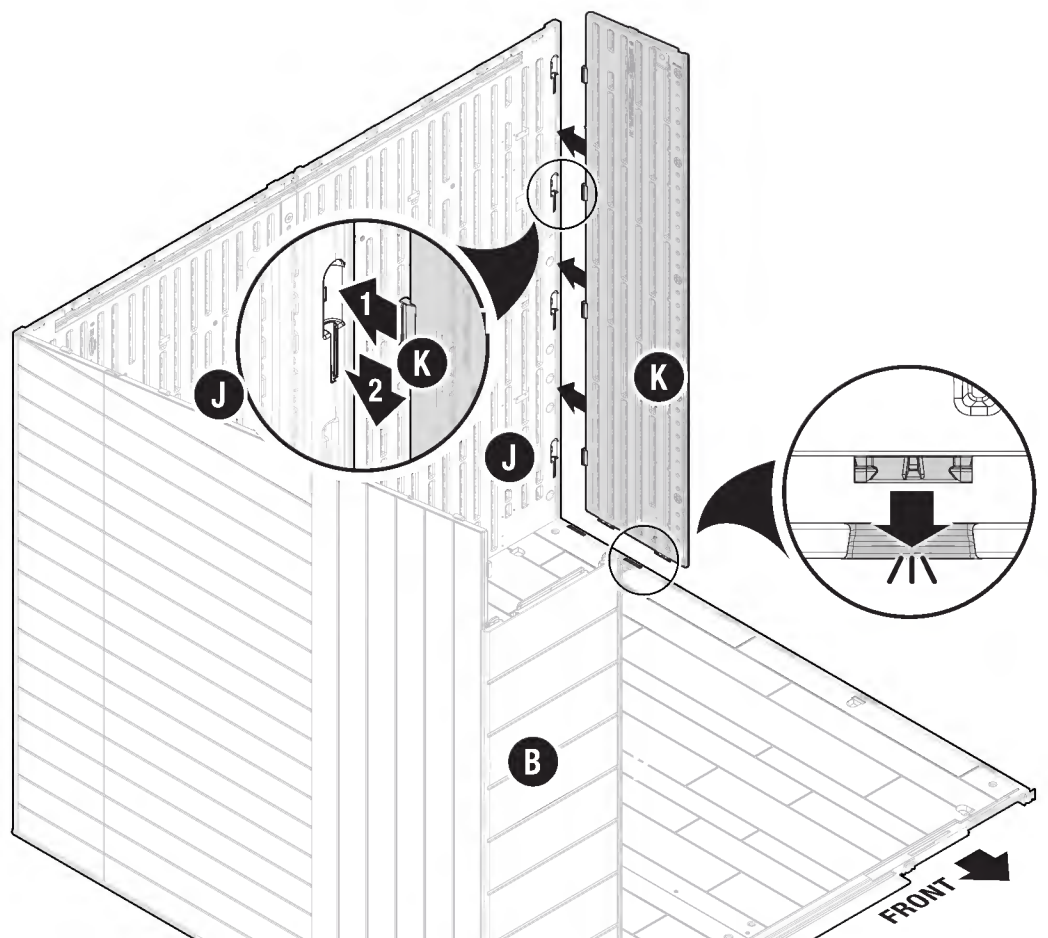





Insert the bottom tabs of right middle side (Y) into the slots of the right floor (B) as shown. Slide the right middle side (Y) towards the corner of the floor (as indicated by the arrow) until it locks into place.

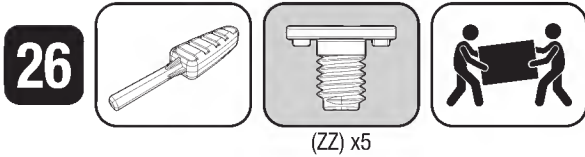
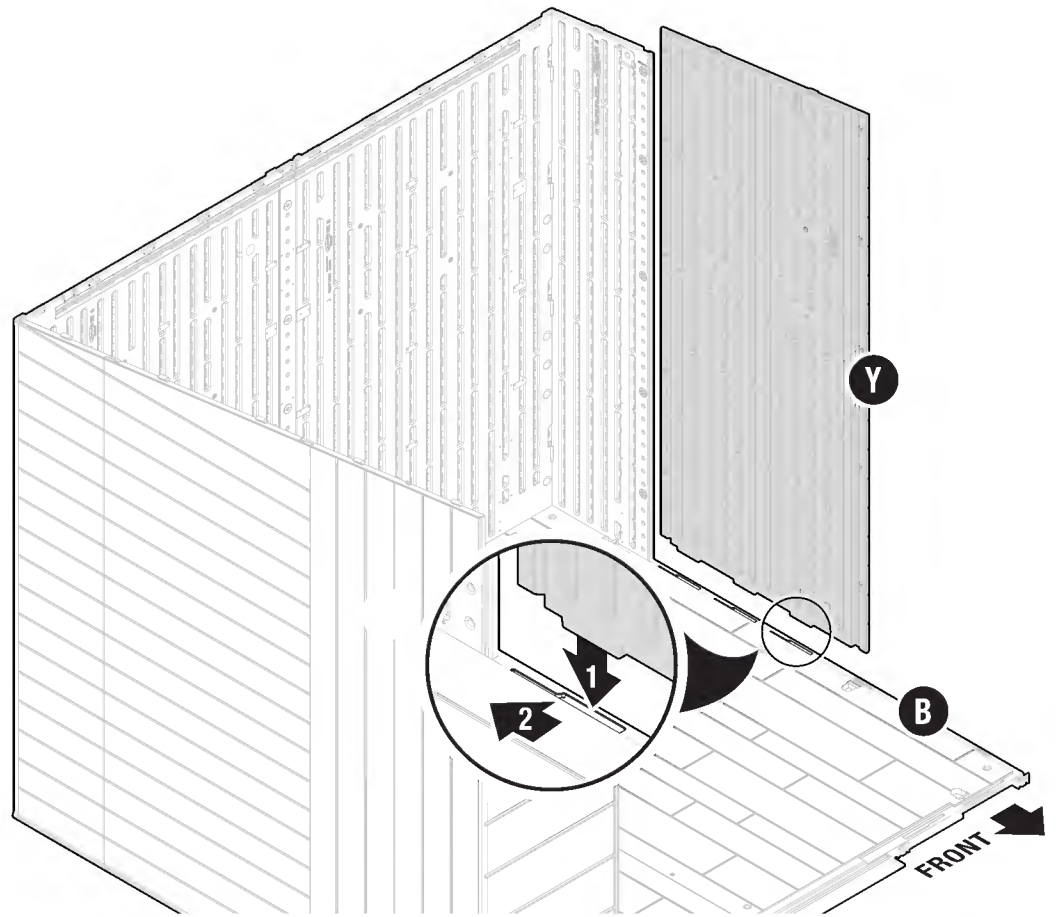

(ZZ) x5

Secure the right back side (K) to the right middle side (Y) using 5 easy bolts (ZZ). Tighten securely (3-4 clicks).

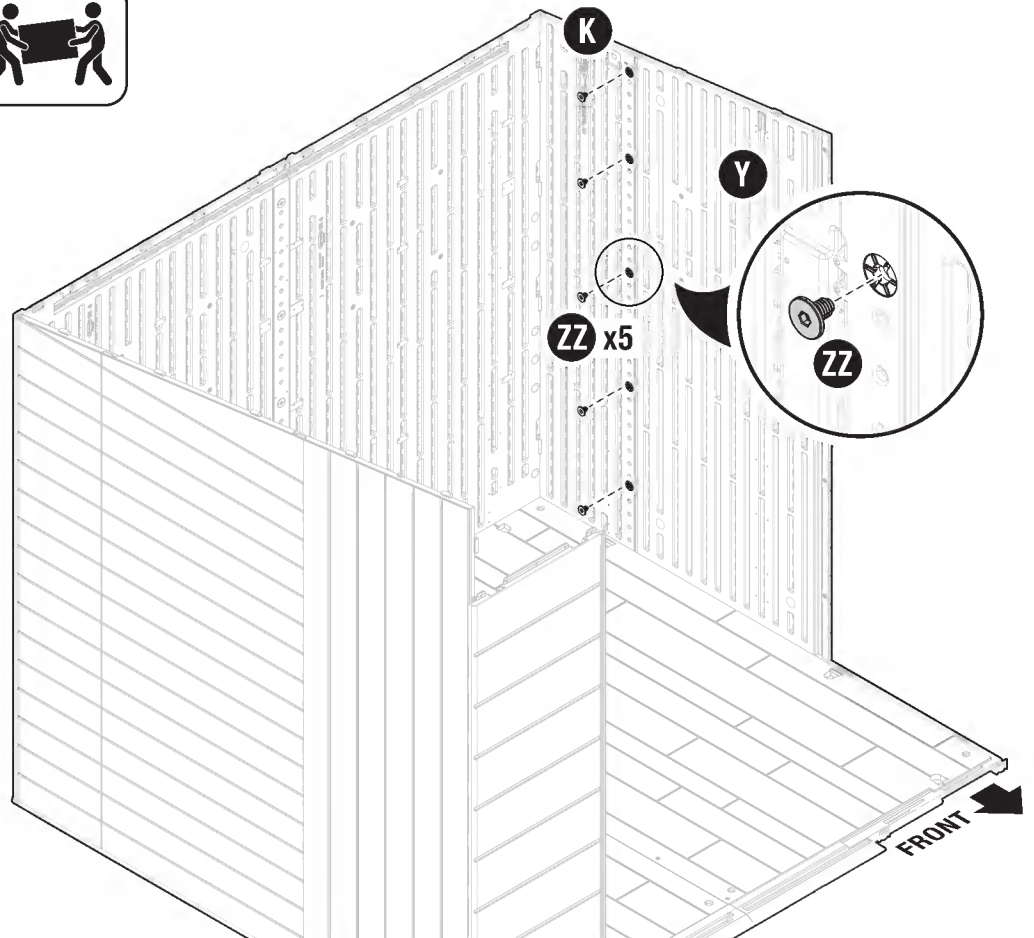



27

Insert the bottom tabs of right front (C) into the slots of the right floor (B) as shown.

Slide the right front (C) towards the corner of the floor (as indicated by the arrow) until it locks into place.

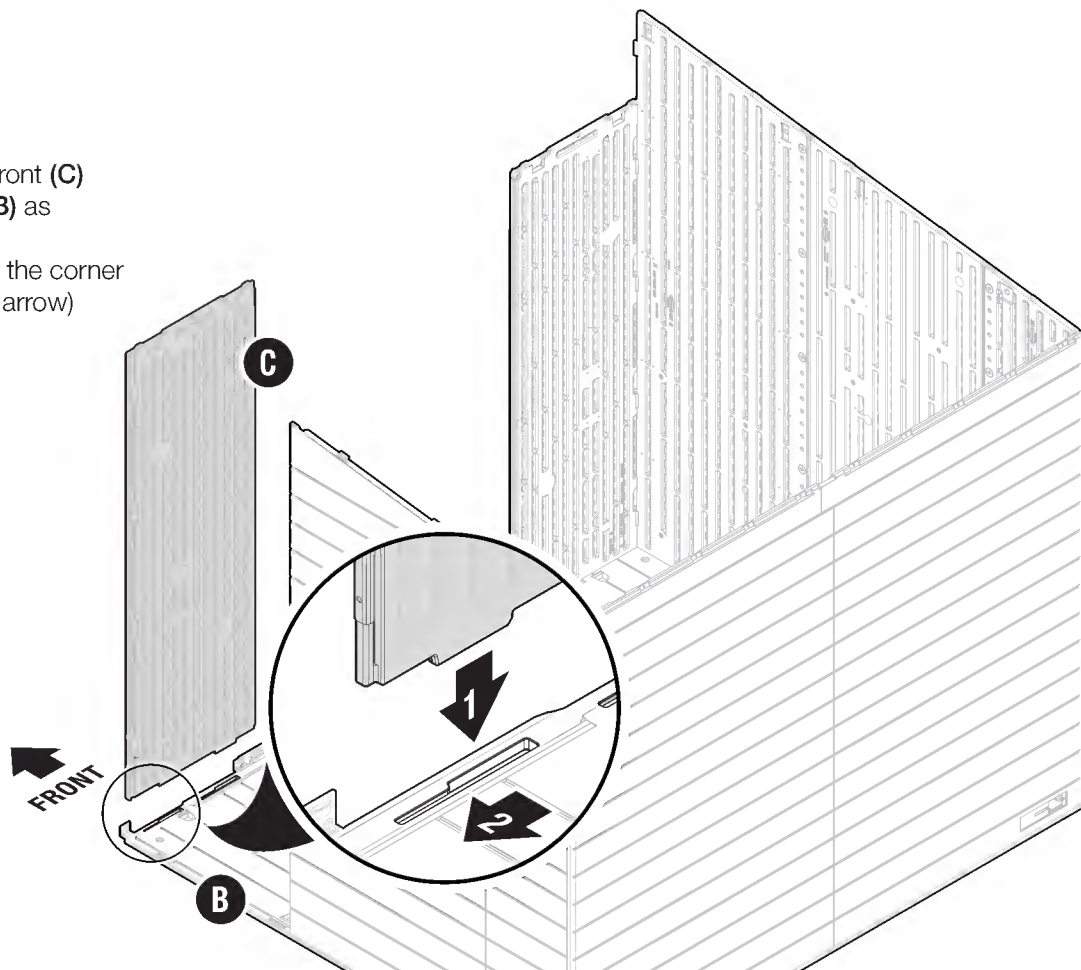

28

Align the side tabs of the right front side (N) with the slots on the right front (C). Slide right front side (N) down to engage tabs.

Continue to press firmly until bottom tabs snap into right floor (B) as shown.

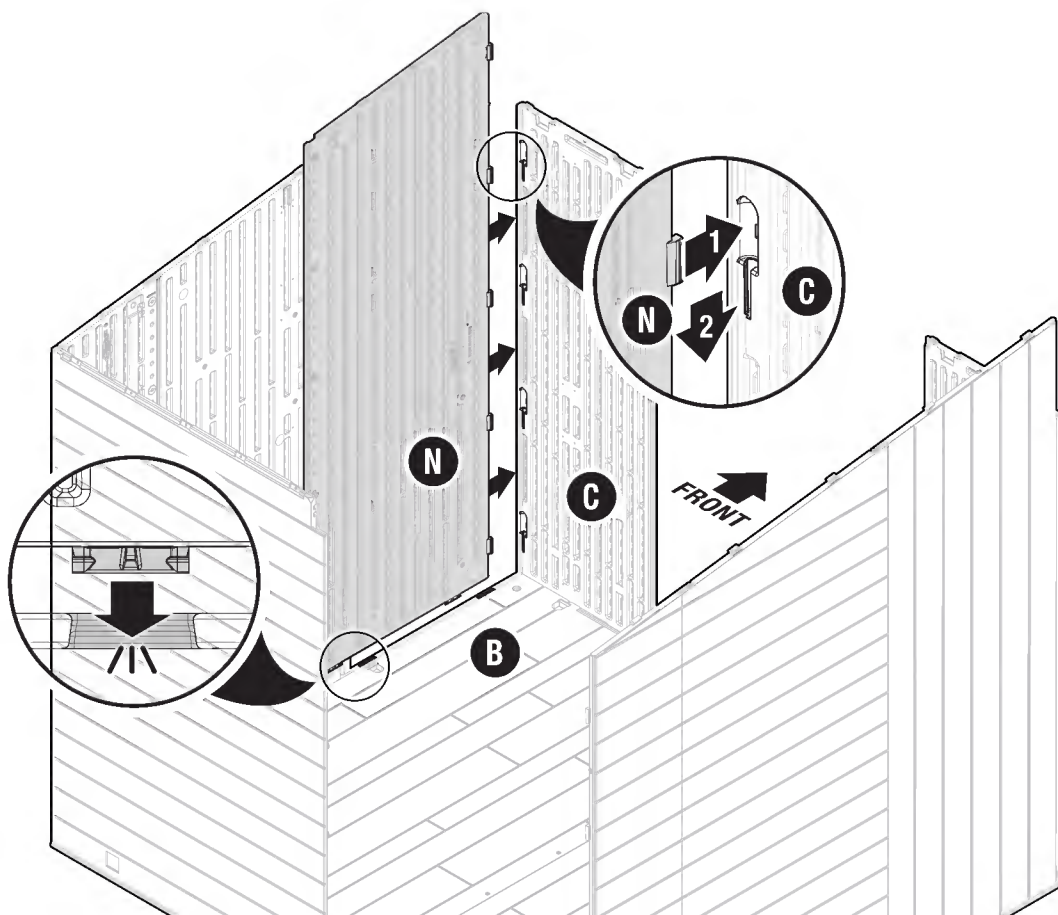

29

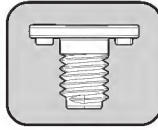
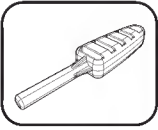

(ZZ x 5)

Secure the right middle side (Y) to the right front side (N) using 5 easy bolts (ZZ). Tighten securely (3-4 clicks).

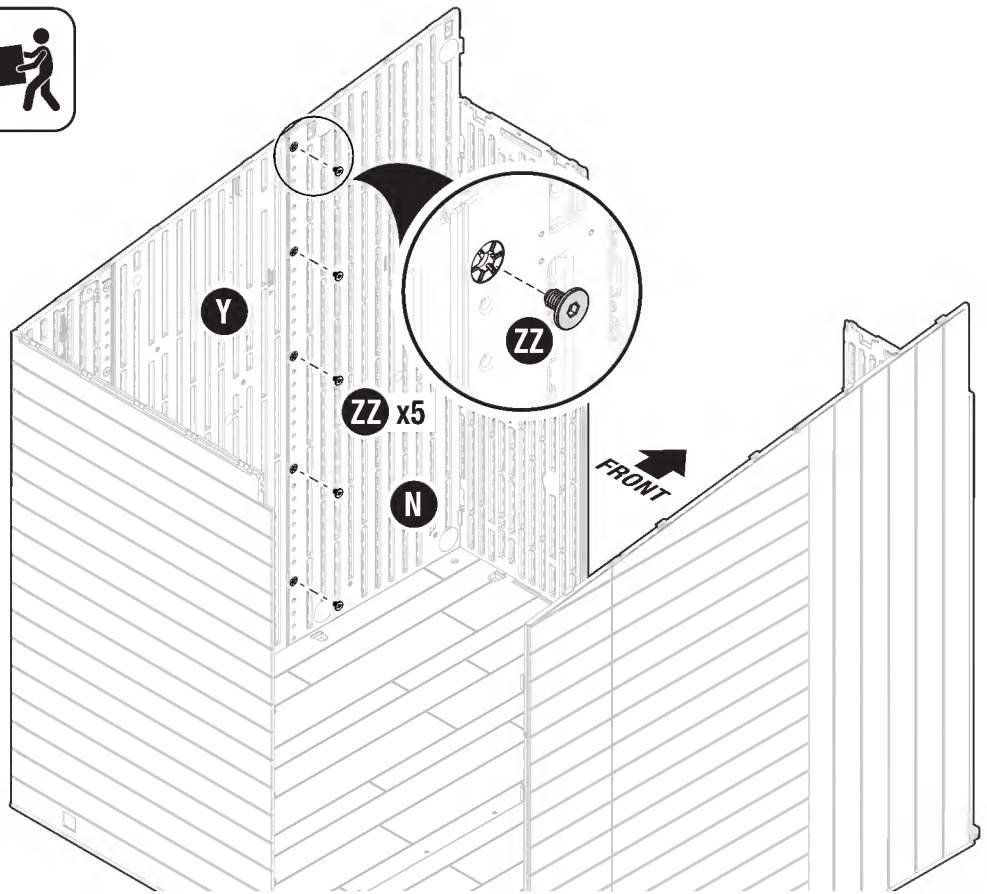

## Assembly - Header

### Required Hardware/ Steel Kits



0480377



30

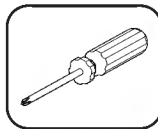
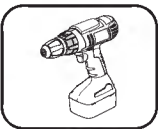

(S) x10

Place header assembly (M,Q) over the left front (E) and right front (C) panels. Align side slots on header assembly with tabs on front sides panels. Once aligned slide header down to engage into slots. Secure header assembly (M,Q) with 10 screws (S).

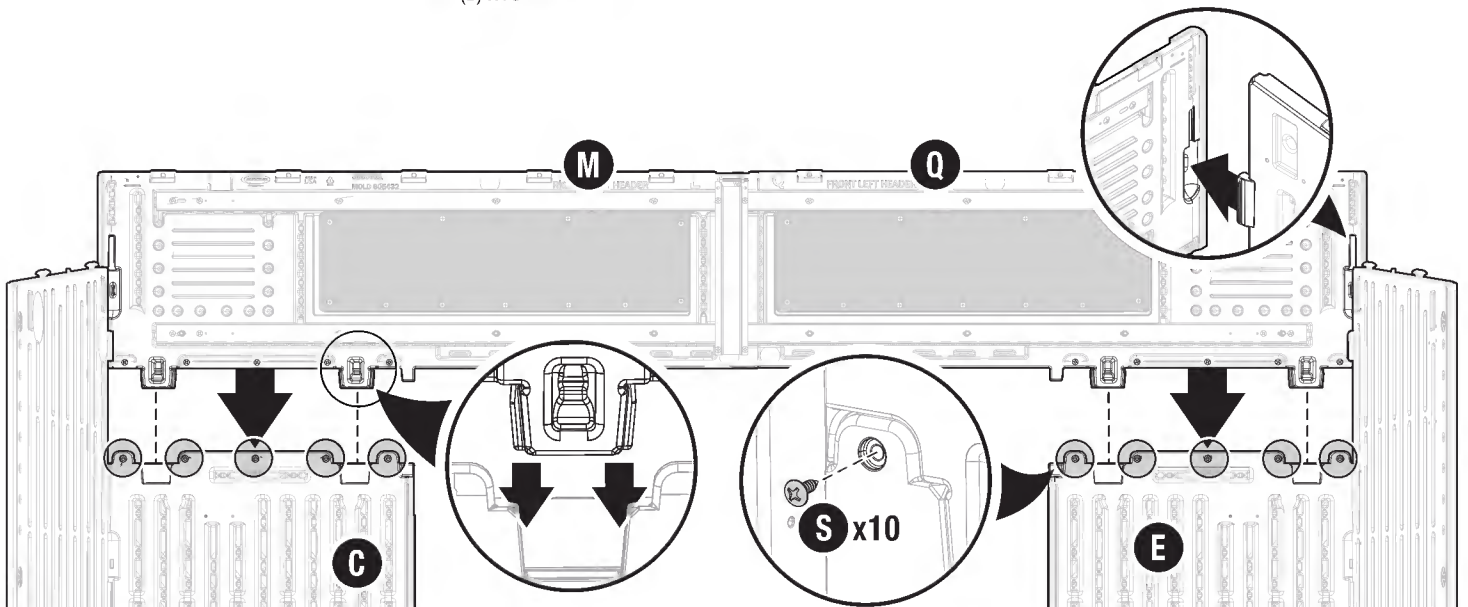

# Assembly - Rear Header Beam

## Required Hardware/ Steel Kits



31

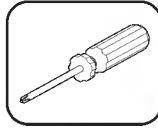
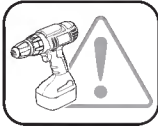

Position header beam (**82"**,**AAA**) across the left and right back panels (**I,J**) as shown. Secure with 4 screws (**S**).

(S) x4

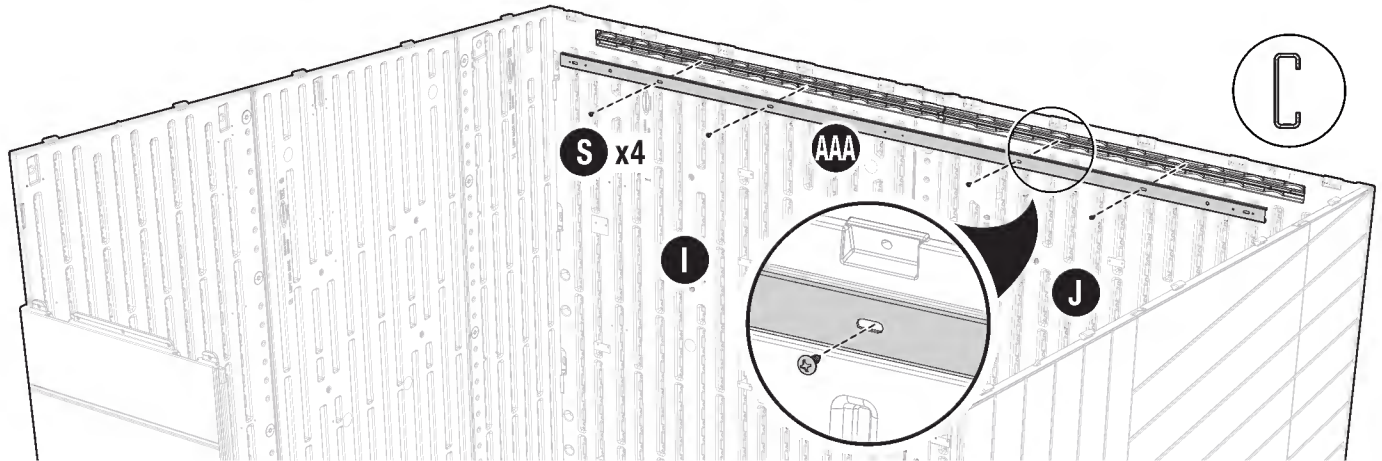

32

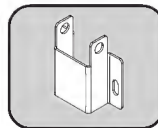
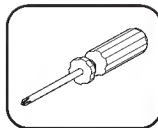

Secure support bracket (**W**) to the back header beam (**AAA**) using 2 screws (**S**).

(S) x2

(W) x1

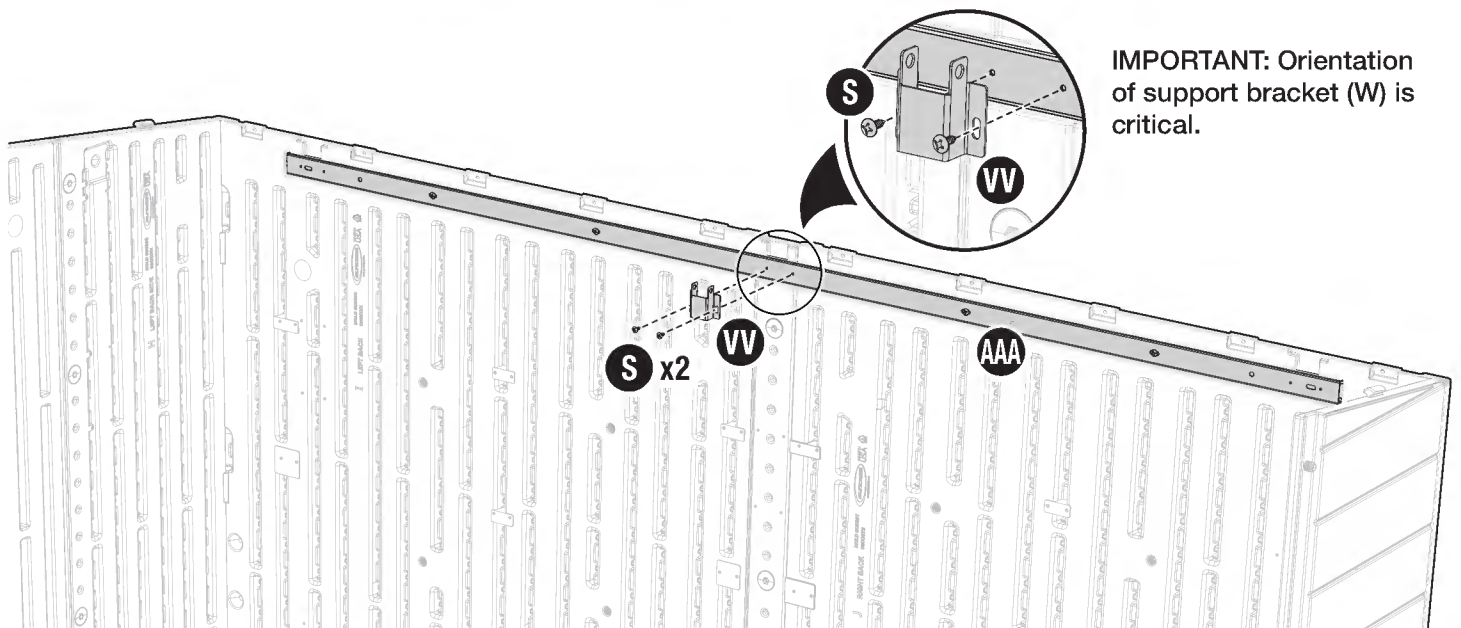

# Assembly - Side Adapters

## Required Hardware/ Steel Kits



33

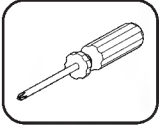

Secure 2 side adapters (68.5", CCC) to the left and right back panels (I, J) using 16 screws (S) each. Reference image below for adapter locations.

**IMPORTANT:**  
Orientation is critical.

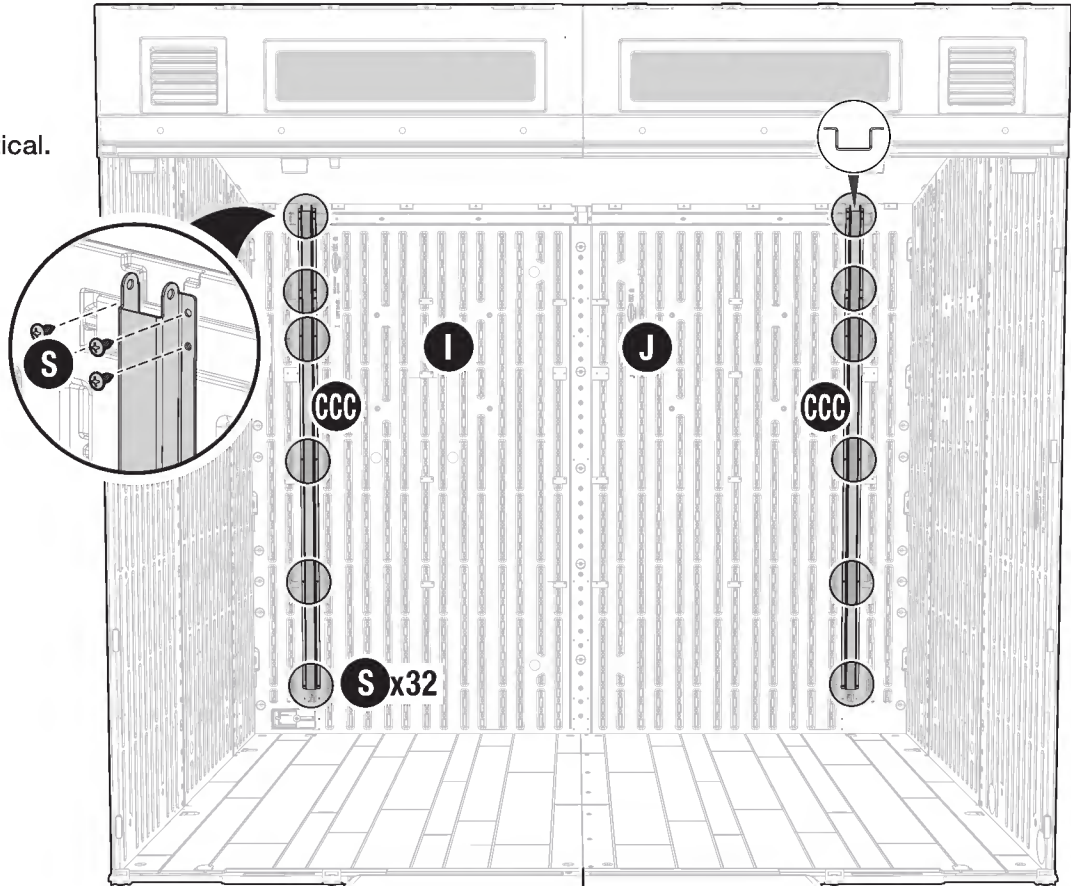

34

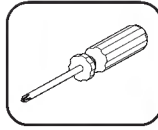
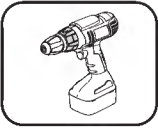

(S) x32

Secure 1 side adapter each (68.5",CCC) to the left middle side (G) and right middle side (Y) using 16 screws (S) each. Reference image below for locations.

IMPORTANT:  
Orientation is critical.

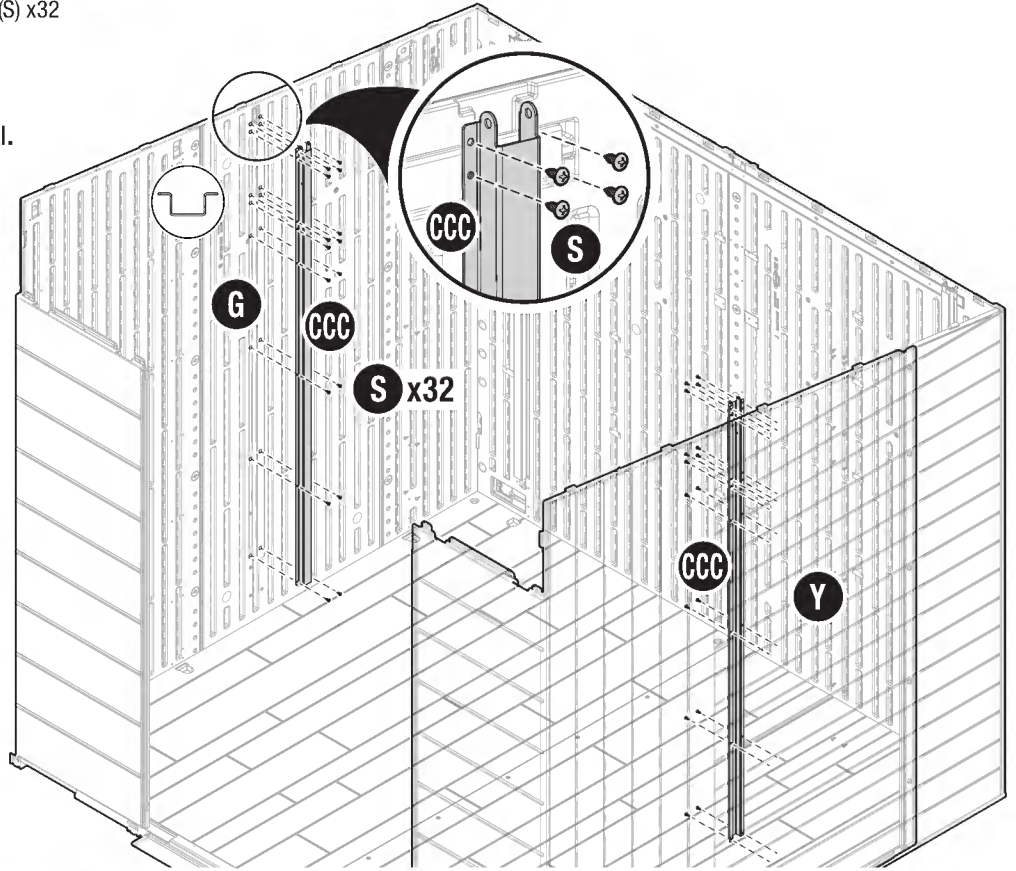

35

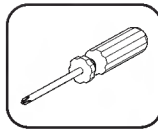
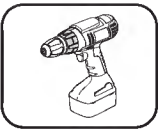

(S) x32

Secure 1 side adapter each (68.5",CCC) to the right and left front panels (C,E) using 16 screws (S) each. Reference image below for adapter locations.

IMPORTANT:  
Orientation is critical.

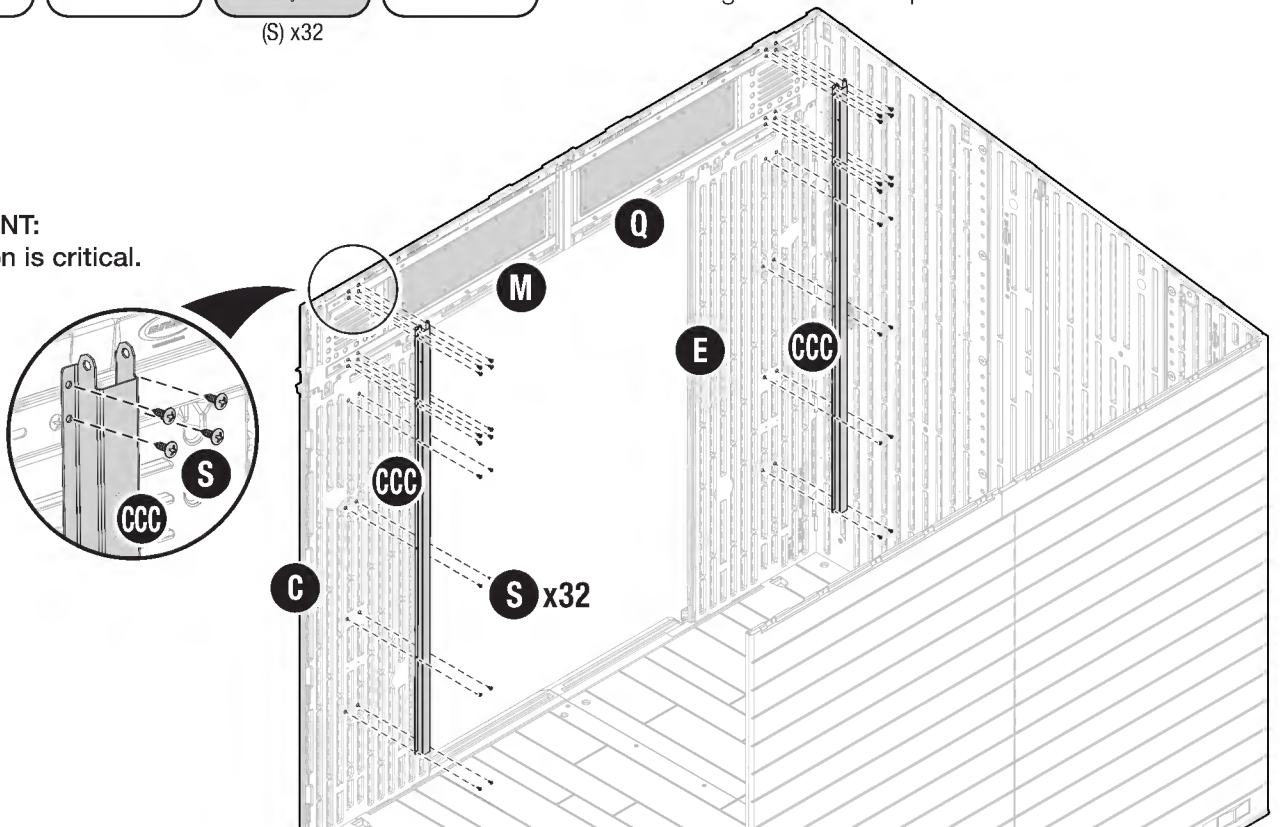

# Assembly - Ridge Beam

## Required Hardware/ Steel Kits



36

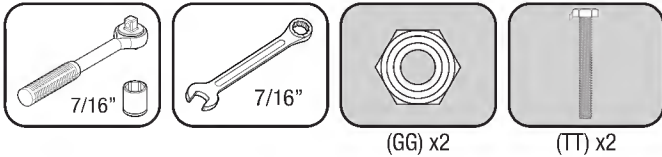

Slide 39" ridge beam (**QQ**) onto 1 end of joiner (**12"**, **SS**). Slide 55.14" ridge beam (**RR**) onto remaining end of joiner (**SS**). Secure ridge beams to joiner using 2 bolts (**TT**) and 2 nuts (**GG**). Tighten securely.

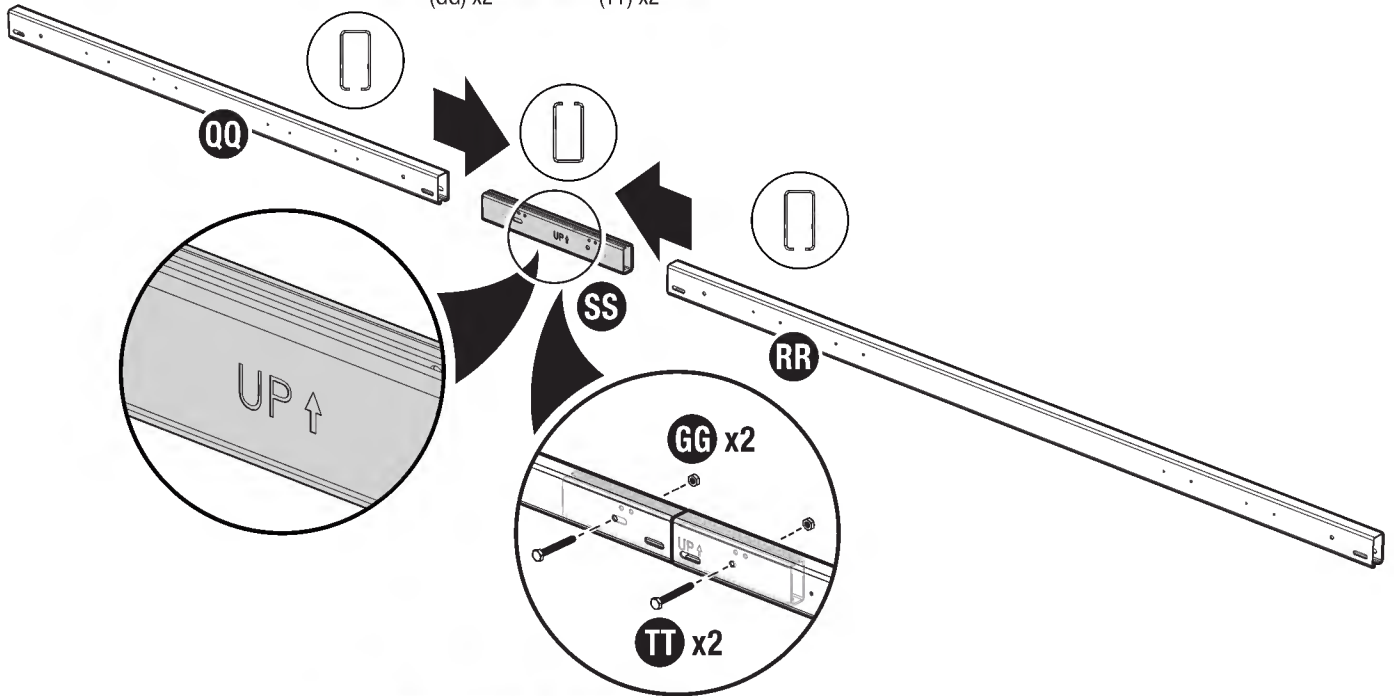

37

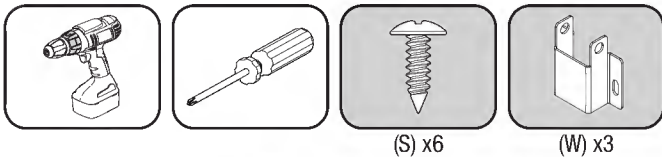

Using 2 screws each (**S**), secure 3 support brackets (**VV**) to ridge beam assembly (**QQ,RR**) at the locations indicated.

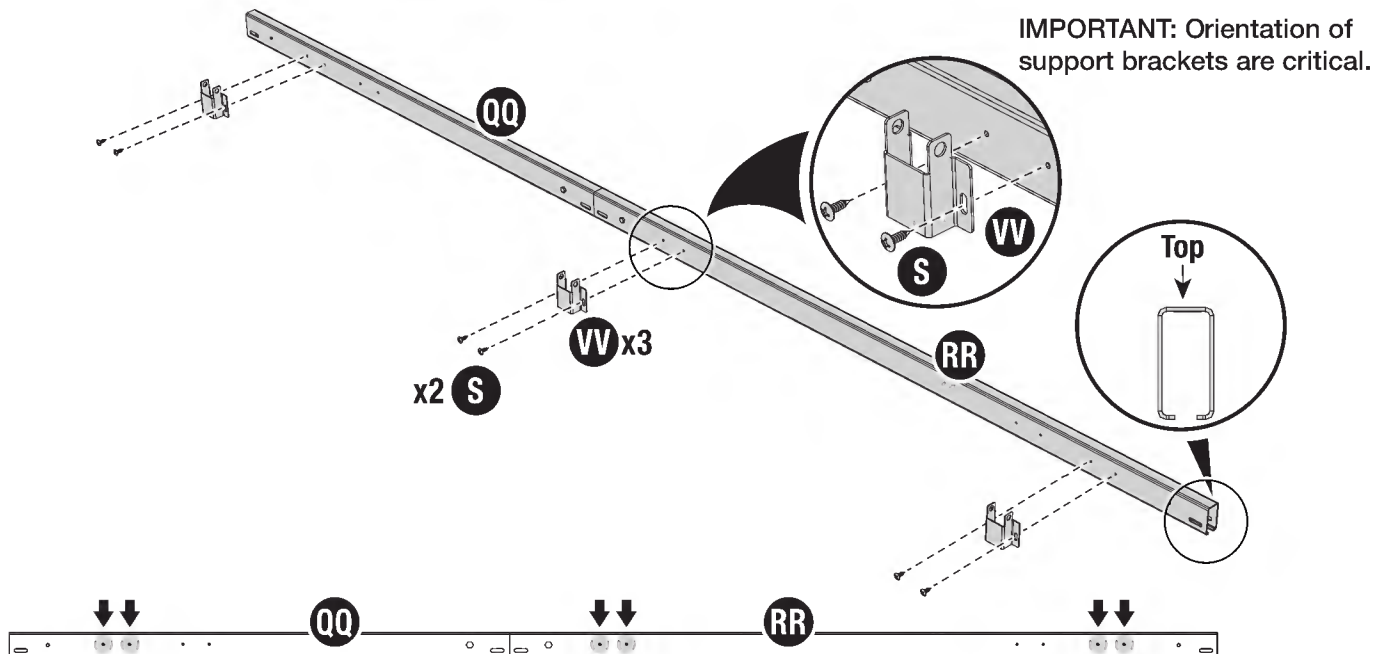

38

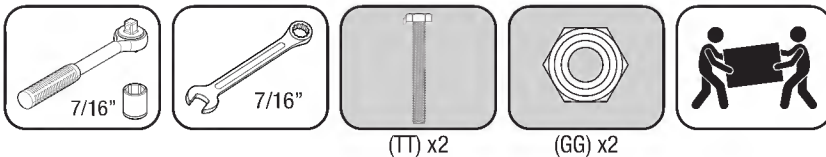

Position the ridge beam assembly, across the right and left side adapters (CCC) as shown. Secure using 1 bolt (TT) and nut (GG) on each end. Leave bolts loose at this time.

**NOTE:** The support brackets (VV) should face the front of the shed.

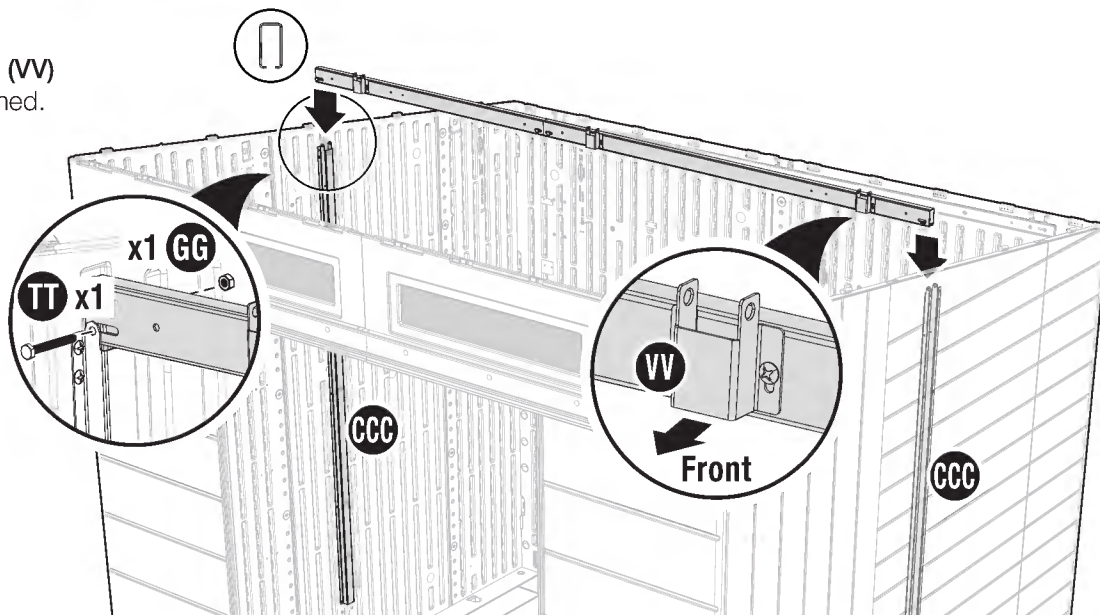

## Assembly - Roof Trusses

### Required Hardware/ Steel Kits



39

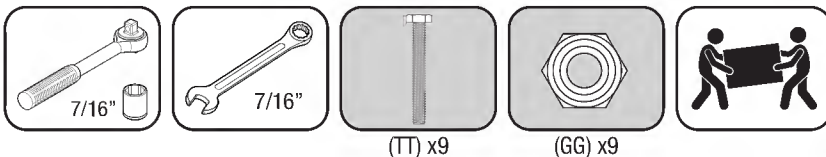

**IMPORTANT:** Orientation of the truss legs (EEE) is critical. Be sure to orient the truss legs with the ends having two holes (\*\*\*) positioned toward the front of the shed.

Place 3 truss legs (82.94",EEE), across the top of the shed so that they align with the side adapters and ridge beam assembly as shown. Secure using one bolt (TT) and nut (GG) at each joining location. Leave bolts loose at this time.

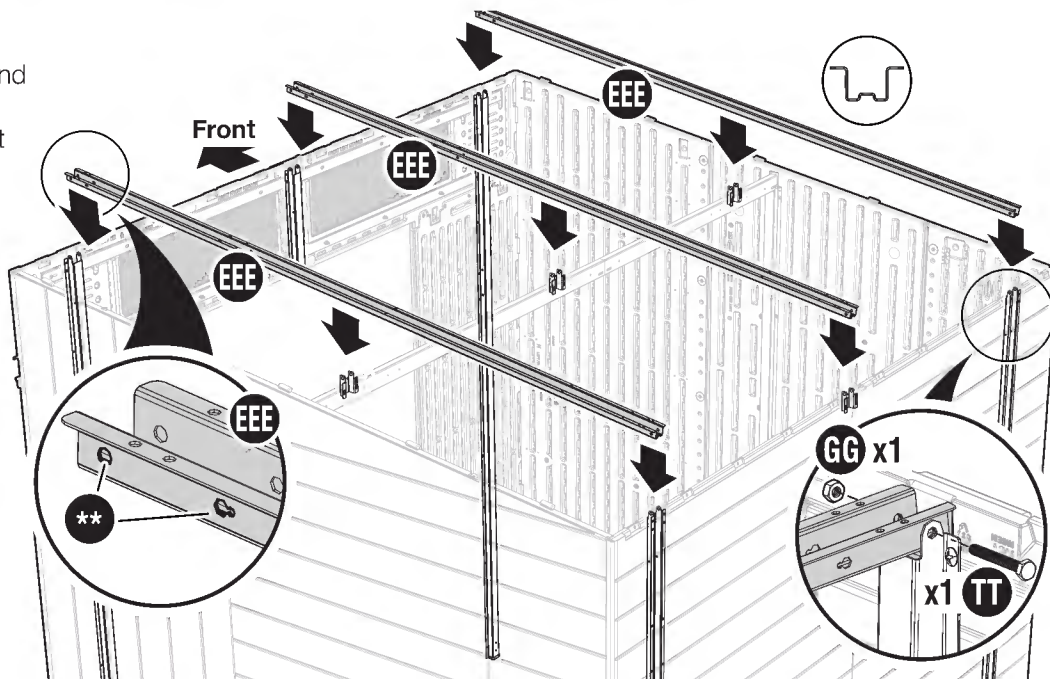



# Assembly - Roof

## Required Hardware/ Steel Kits



40



Identify the 5 slots on 1 roof panel (**P**), and the 5 tabs on side panels (**N,Y,K**). Lay roof panel over the 5 tabs on the side panels (**N,Y,K**) as indicated, then line up with the tabs on the right side of the shed. **IMPORTANT:** The wide band of the roof panel faces the front of the shed.

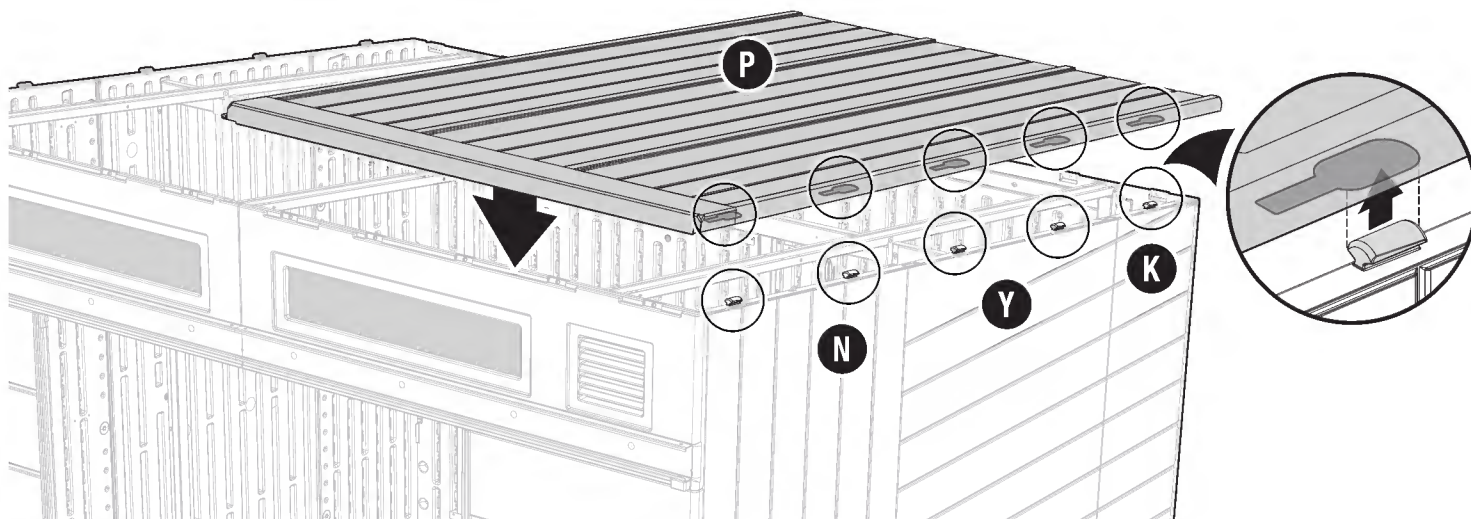

41

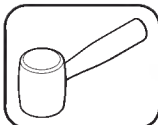



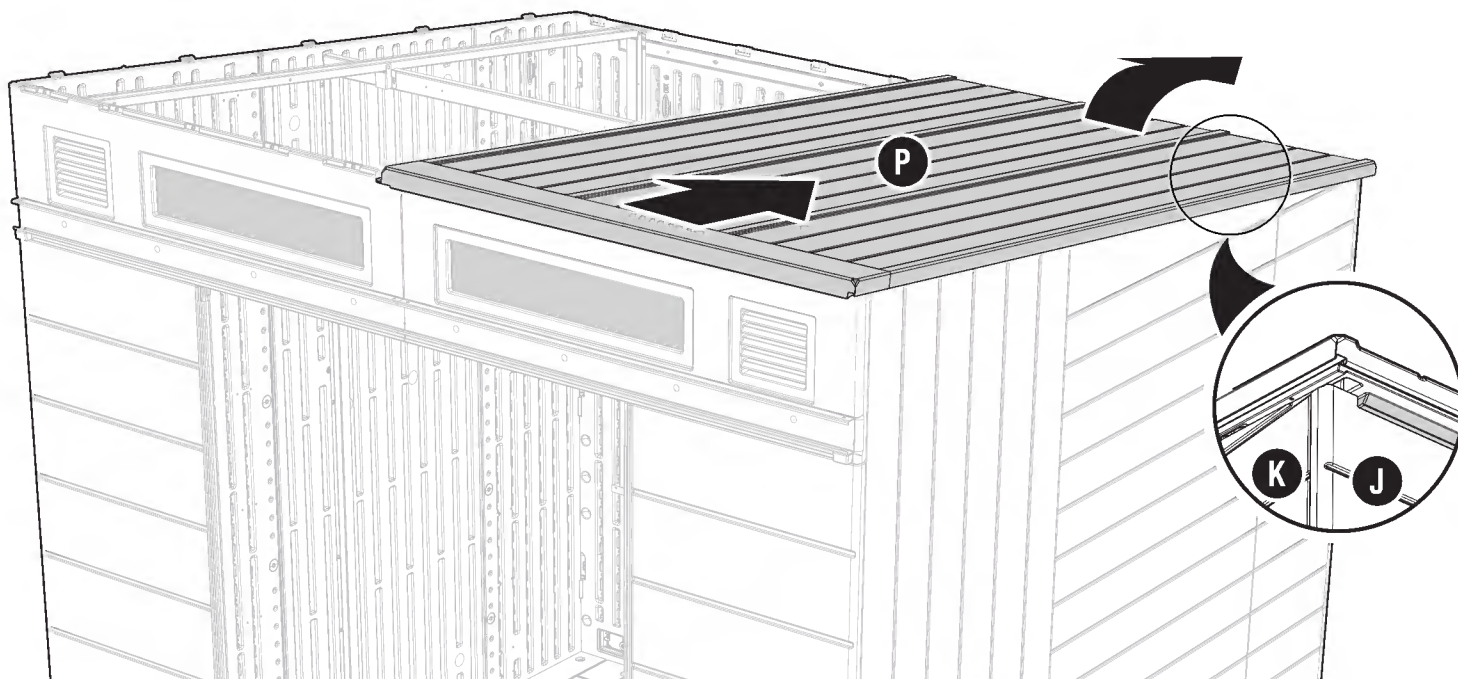

Once 1 roof (**P**) is in position, from the outside of the shed have a person hold the roof panel in place while a second person slides the roof towards the back of the shed until the roof is fully engaged.

**IMPORTANT:** The roof is fully locked in position when the ridge of the roof sits over the top of the back panel. Check the slot locations on the roof to ensure they have fully engaged with the tabs before proceeding.

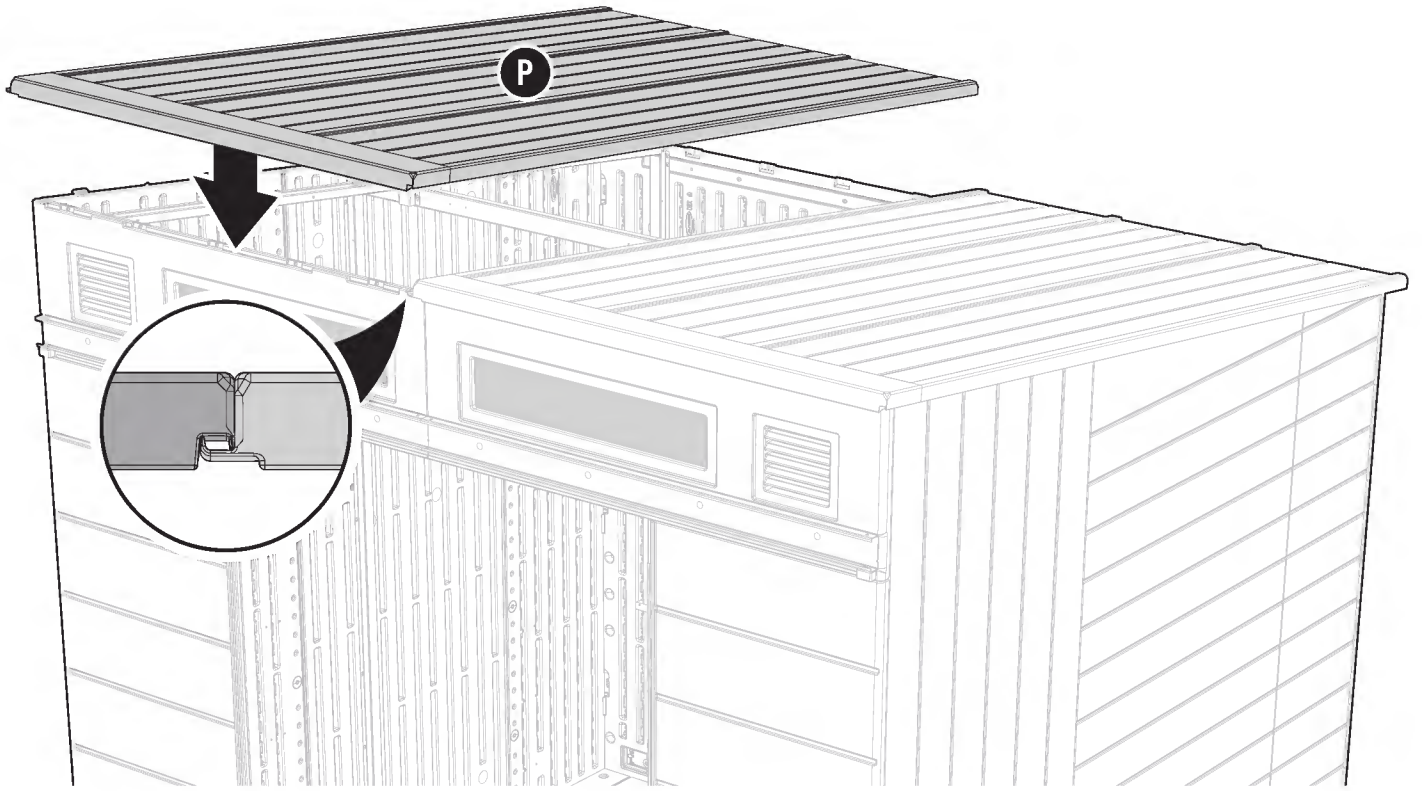

Repeat steps 40-41 to install the remaining roof panel (P) over the left side of the shed.

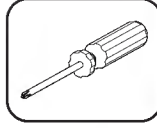

**42**    

(S) x10

Secure roof panels (P) to the left and right back panels (J,I) using 5 screws (S) each.

**IMPORTANT:** With the help of another person, pull down slightly on outer roof panel edges while inserting screws.

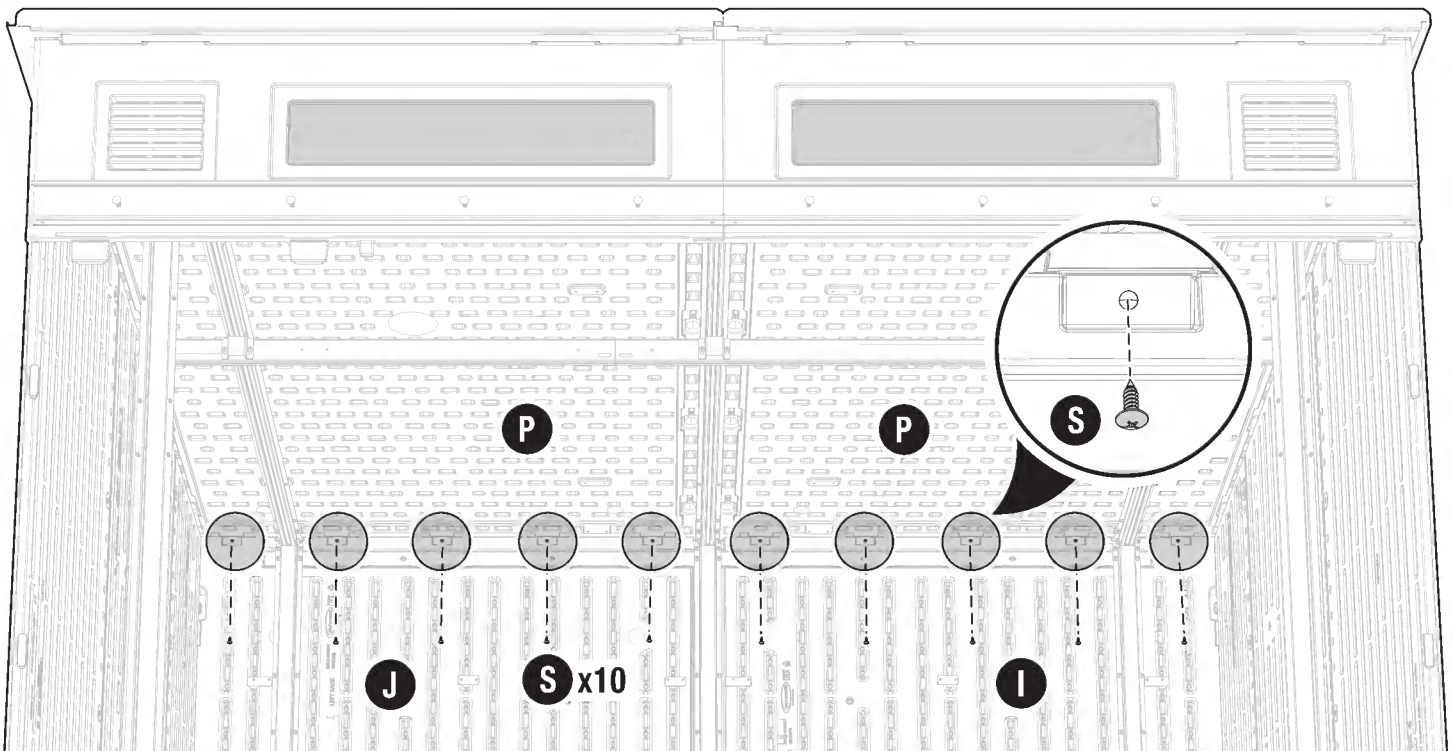

43

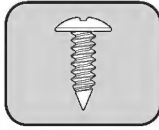
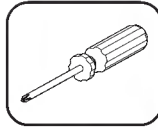
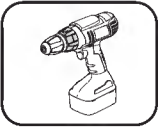

(S) x10

Secure roof panels (P) to the header assembly (M,Q) using 5 screws (S) each.

**IMPORTANT:** With the help of another person, pull down slightly on outer roof panel edges while inserting screws.

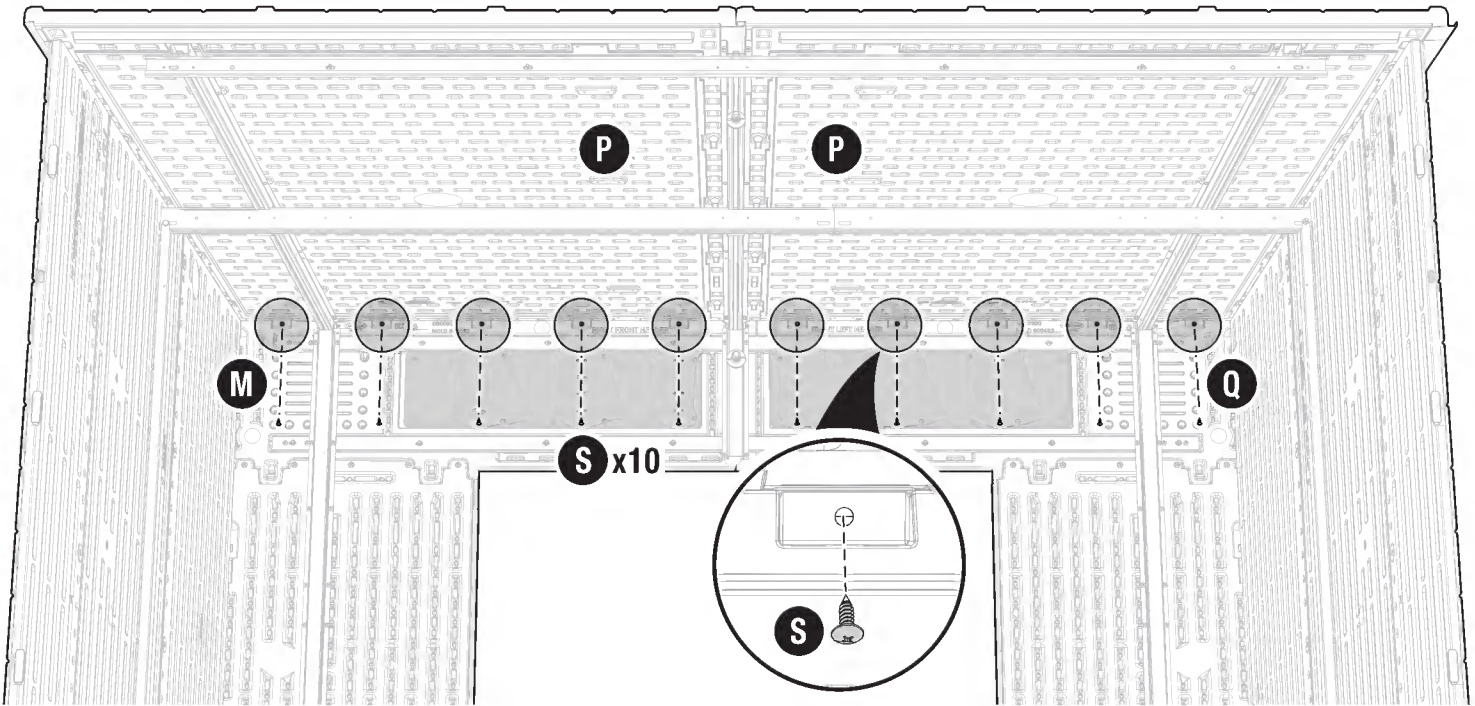

44

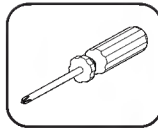
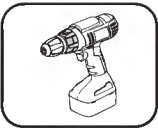

(S) x48

Secure the 3 truss legs (EEE) to the roof panels (P) at the locations indicated using 16 screws (S) each.

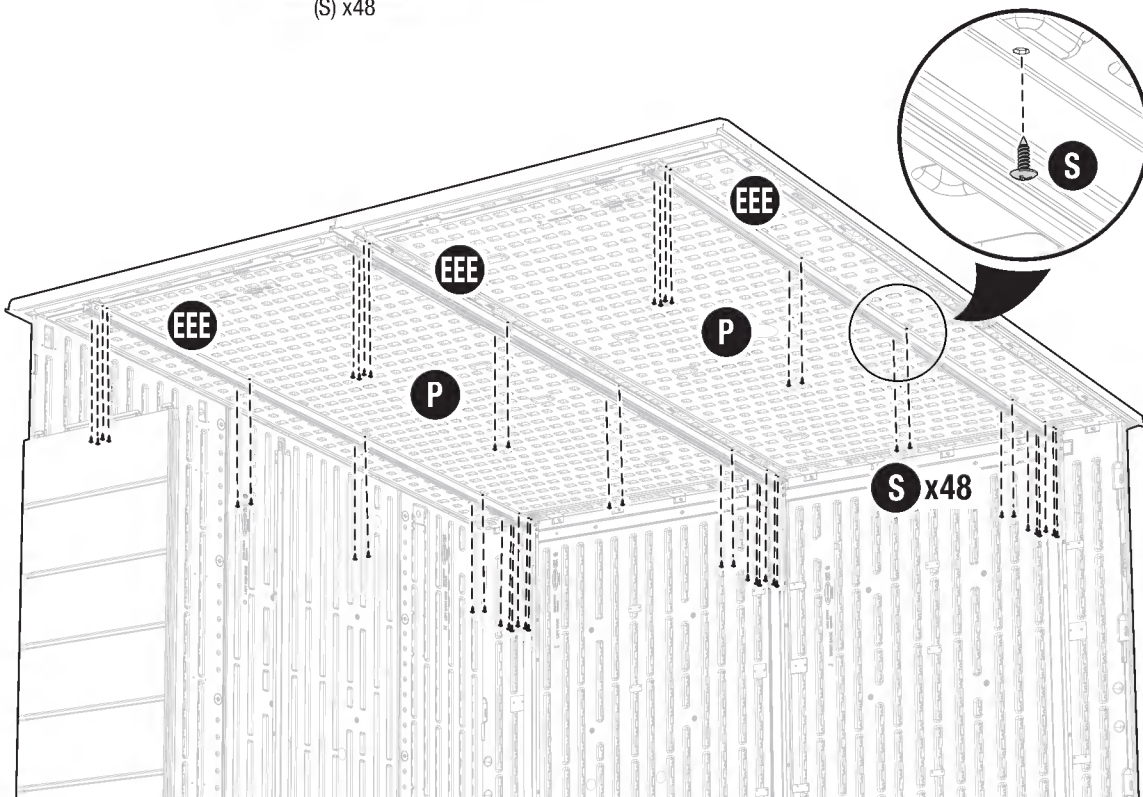

45

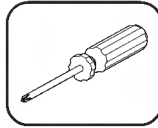
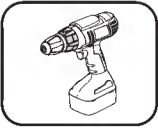

(S) x16

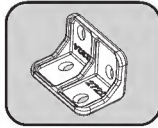

(BBB) x4



At the locations indicated, secure roof brackets (BBB) to the top of the front right headers (M,Q) and roof panels (P) using 16 screws (S).

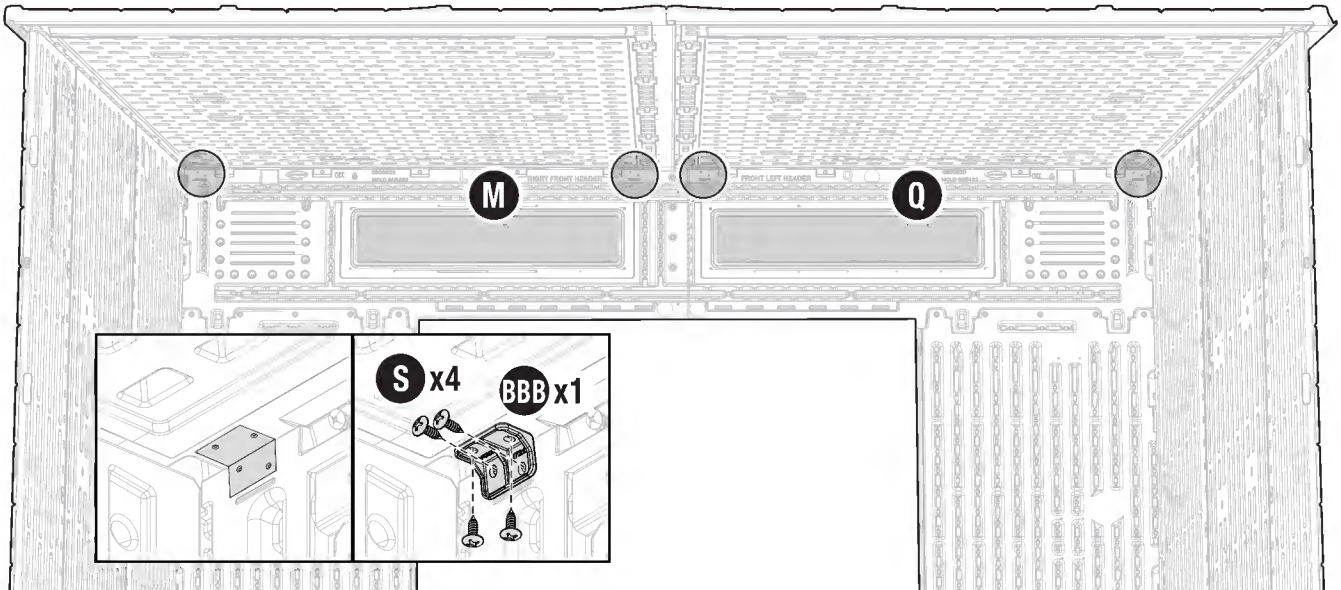

## Assembly - Doors

### Required Hardware/ Steel Kits



46



With the gutter (53",U) orientated as shown, slide gutter (U) in-between the left and right headers (Q,M) and the previously installed door track (MM). Once gutter (U) is in position, tighten the 8 bolts (NN) and nuts (OO).

**IMPORTANT:** Be sure the top edge of the gutter (U) is making contact with the previously installed carriage bolts (NN) before securing.

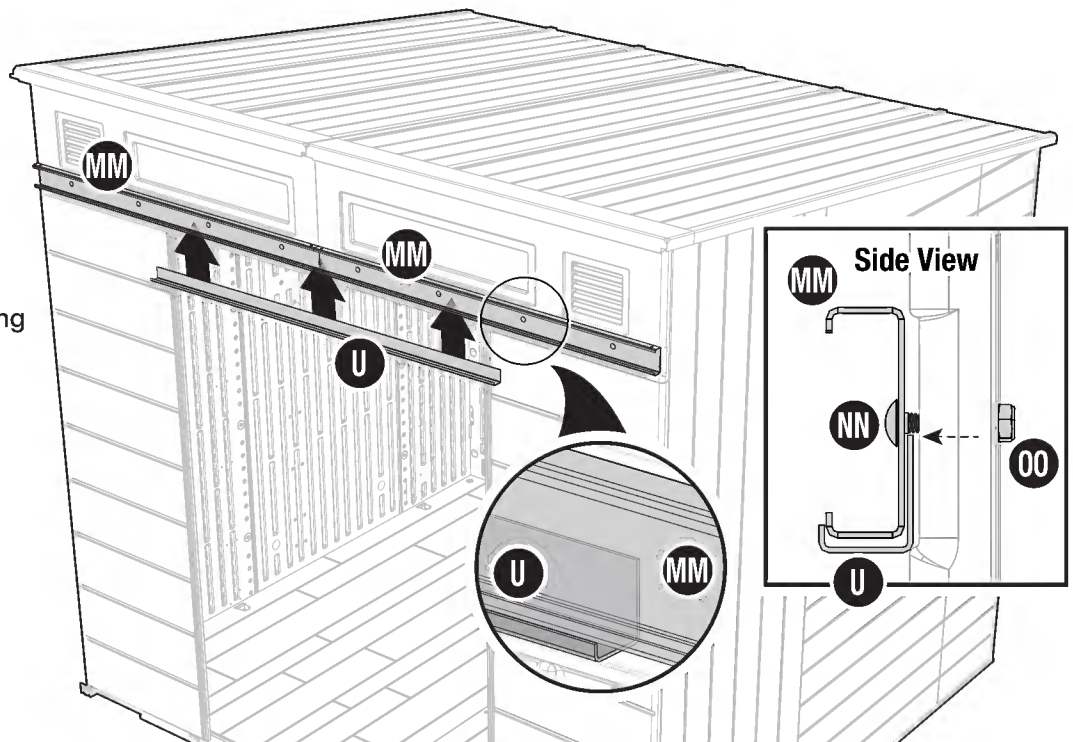

47



From the left side of the shed align the left door (L) with the door track (MM) and door guides (R) as shown. Slide door towards the center of the shed to engage.

Repeat process from the right side of the shed to install the right door (D).

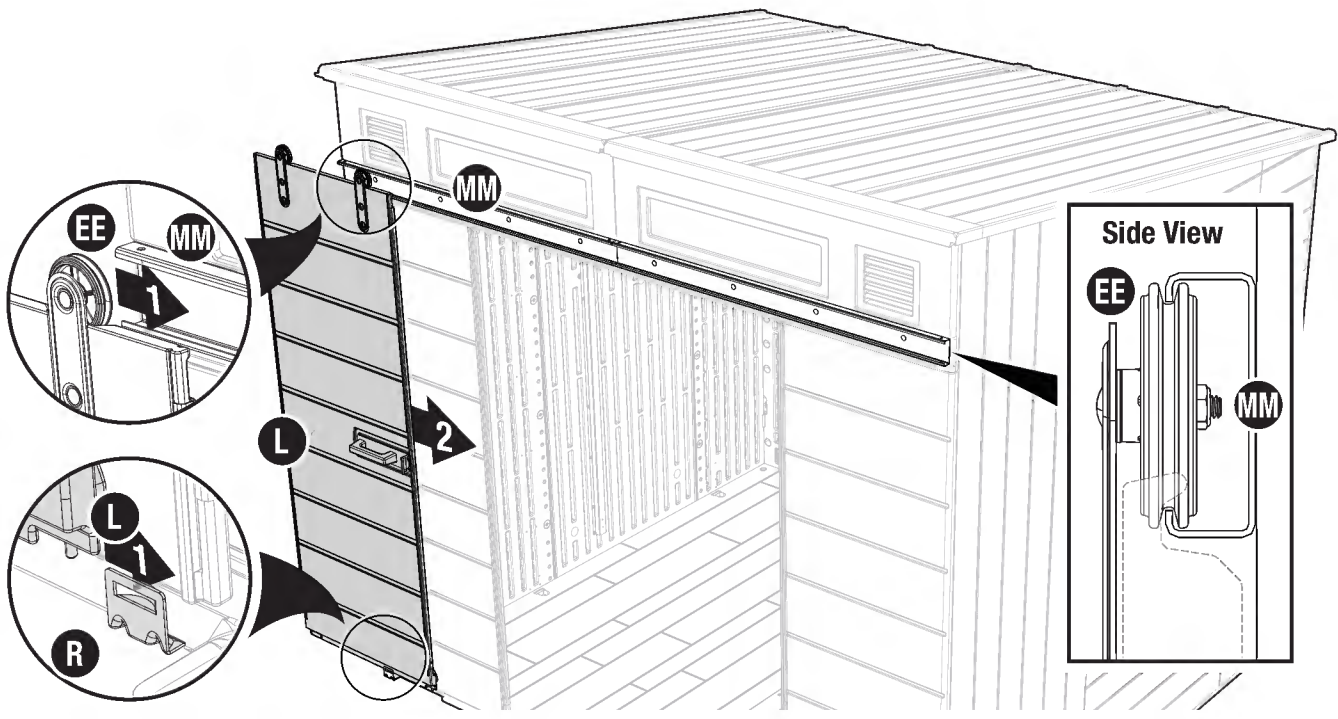

48

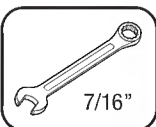

7/16"



(JJJ) x2

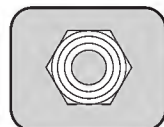

(GG) x2

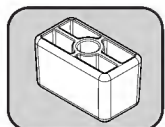

(HHH) x2

Install 1 bumper (HHH) to the right side of door track (MM) using 1 bolt (JJJ) and nut (GG). Repeat for left side of door track.

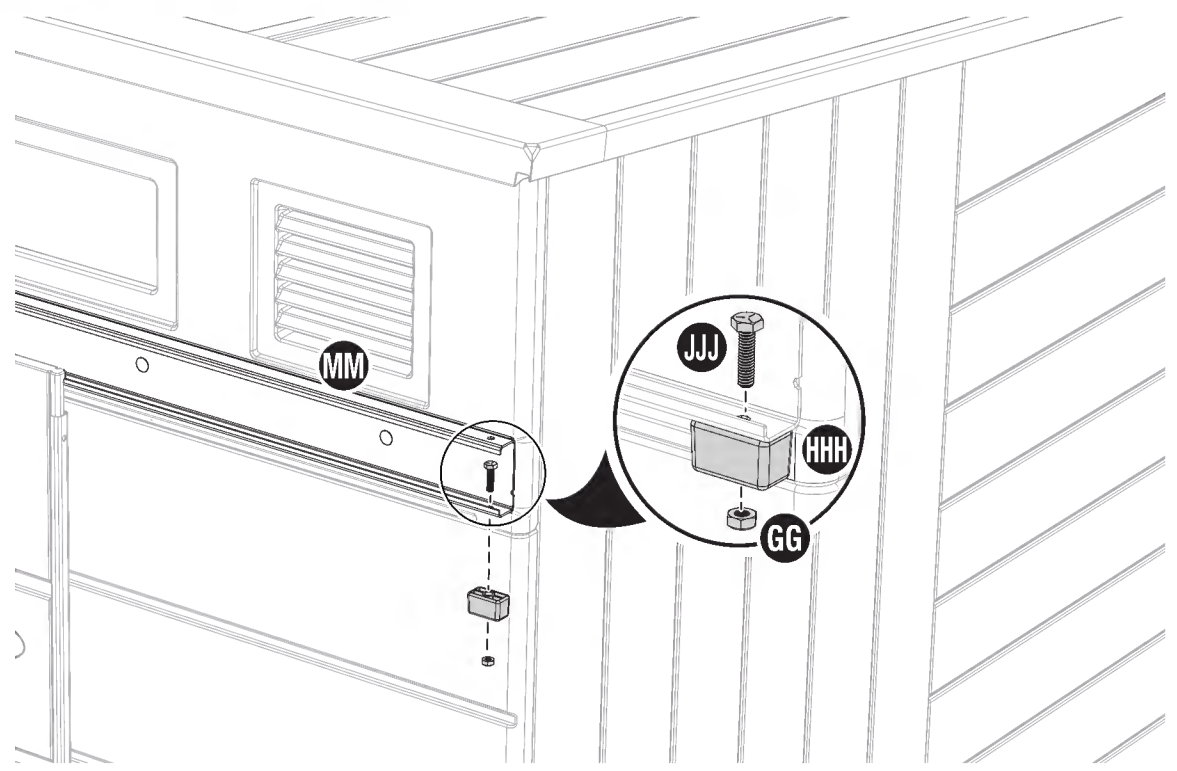

# Assembly - Tool Hanger Accessory

**Important:** Only Use the Easy Bolt hole in the hanger when mounting to shed panels.

## Installation

Align the hanger with the desired shed wall hole. Insert 1 Easy Bolt (ZZ). Tighten securely (3-4 clicks).

**NOTE:** Easy bolts for included shed accessories are provided in Easy Bolt hardware bag within the parts kit. Please note, only model BMS8780T includes shed accessories with the product.

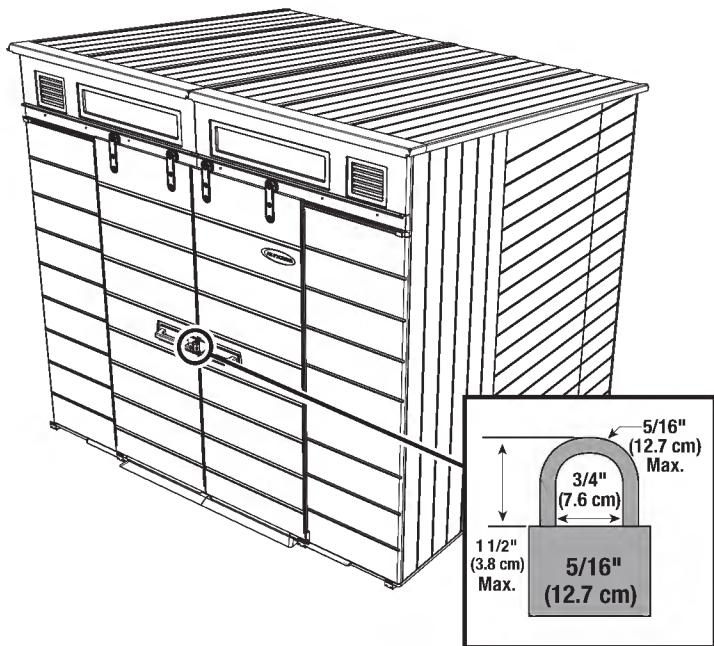
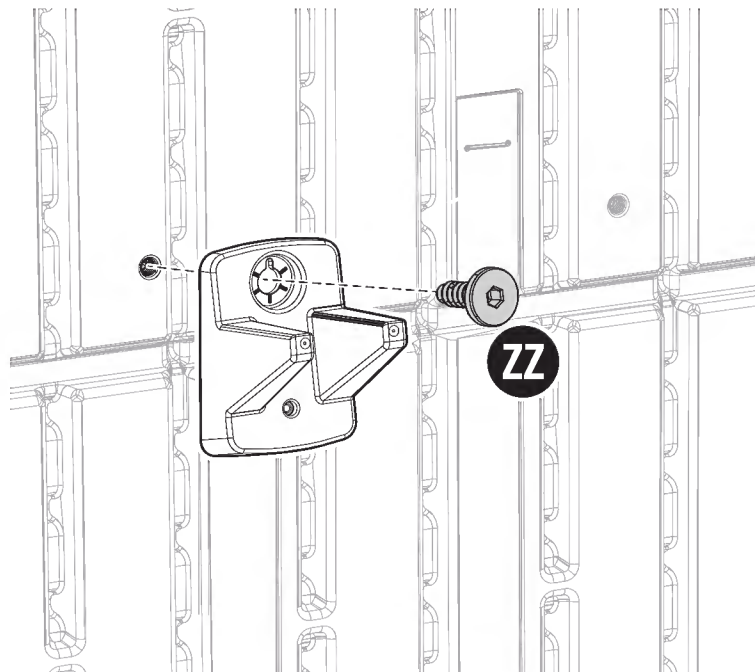

Attach a 5/16" lock (not provided) to door latch to properly secure shed.

**NOTE:** To maintain warranty coverage, the product should be padlocked at all times when not in use.

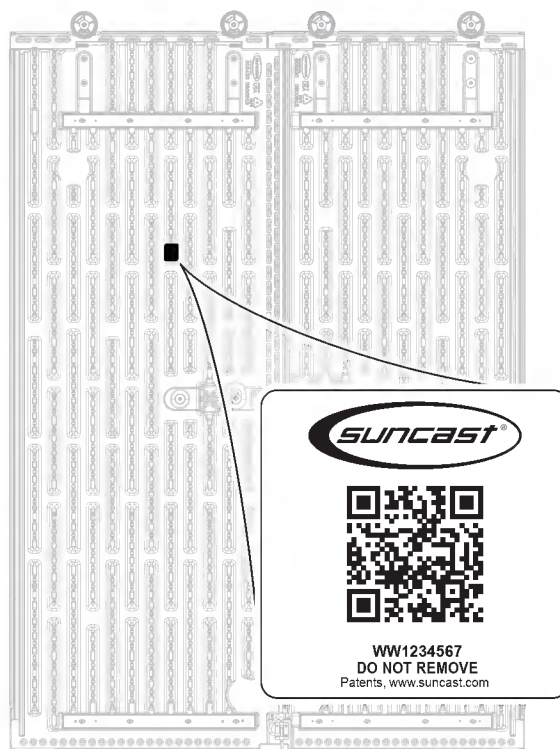

This label located on the inside of door contains information regarding your product. The QR code is a direct product link to the product registration page on the Suncast website. The codes at the bottom of the label are specifically related to your product. Please have these numbers available should you need to contact Suncast.



